



Spacemaster® SX1 Electric Wire Rope Hoists

Innovation . . . Performance . . . Reliability



www.rmhoist.com

The ideal hoist for monorails, jibs and light crane systems



Space-Efficient
Low Headroom Hoist



Double Girder Hoist
Capacities to 80 Ton



QX Crane Packages



Standard Configurations

- *1 ton and 2 ton capacities with ASME H4 duty rating*
- *1000 kg and 2000 kg capacities with FEM 2m duty rating*
- *Integrated low headroom trolley*
- *Two speed hoisting - 1 ton 32/5.3 fpm (9.6/1.6 m/min)
- 2 ton 16/2.6 fpm (4.8/0.8 m/min)*
- *Two speed trolley travel - 78/19.5 fpm (24/6 m/min)*
- *Push button pendant (E-stop, 2H, 2T)*
- *208, 230, 460, 575/3/60 or 380/3/50 power supply*





Spacemaster® SX1

Electric Wire Rope Hoists

4501 Gateway Blvd.
 Springfield, OH 45502
 Phone: (937) 328-5100
 Fax: (937) 325-5319
 Nationwide Toll-Free:
 1-800-955-9967

Bulletin No. SX1-2009
 © 2009 R&M Materials Handling, Inc.

Spacemaster® is a registered trademark of R&M Materials Handling, Inc.

- Hoist motor is class F insulated, 60% effective duty and thermally protected
- Near true vertical lift (approx. 1/8" hook drift per foot of lift)
- 40:1 drum to rope diameter ratio extends rope life
- Two-speed contactor controls for hoist and trolley motions (option for VFD hoist controls is not available)
- Block actuated upper limit switch
- Lower limit switch
- Mainline contactor
- IP55 / NEMA 4 type control enclosure rating
- Disc brakes on hoist and trolley motors
- Crown tread trolley wheels (option for patented track is not available)
- Trolley bumpers

Model SX1 021

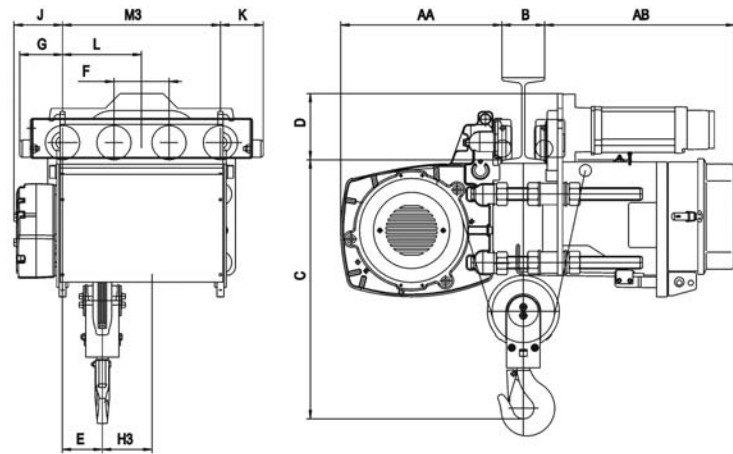

Model SX1 041

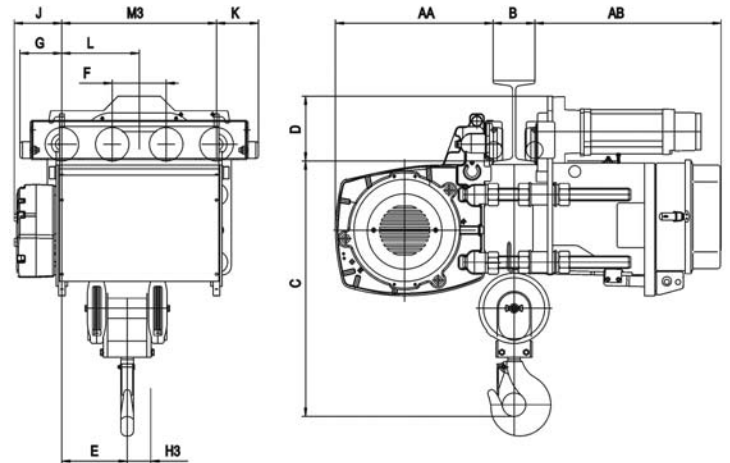

Model / Capacity	Lift	AA	AB	B	C	D	E	F	G	H3	J	K	L	M3
	Ft.	inch	inch	inch	inch	inch	inch	inch	inch	inch	inch	inch	inch	inch
SX1 021 1 Ton	19'-8"	14.82	16.3	2.95...11.81	23.82	6.1	3.66	5.07	3.94	2.22	4.47	3.94	7.26	14.5
	39'-4"	14.82	16.3	2.95...11.81	23.82	6.1	3.66	5.07	3.94	4.39	4.47	3.94	7.26	14.5
SX1 041 2 Ton	19'-8"	14.82	16.3	2.95...11.81	23.94	6.1	6.14	5.07	3.94	2.2	4.47	3.94	7.26	14.53
	29'-6"	14.82	16.3	2.95...11.81	23.94	6.1	6.14	5.07	3.94	3.31	4.47	3.94	7.26	18.86
	m	mm	mm	mm	mm	mm	mm	mm	mm	mm	mm	mm	mm	mm
SX1 021 1000 kg	6	376.5	444	75...300	605	155	93	128.7	100	56.5	113.5	100	184.5	369
	12	376.5	444	75...300	605	155	93	128.7	100	111.5	113.5	100	184.5	369
SX1 041 2000 kg	6	376.5	444	75...300	608	155	156	128.7	100	56	113.5	100	184.5	369
	9	376.5	444	75...300	608	155	156	128.7	100	84	113.5	100	184.5	479

R&M Materials Handling, Inc. is a proud member of the following organizations:



R&M Materials Handling, Inc. may alter or amend the technical specifications identified herein at any time with or without notice.

YOUR DISTRIBUTOR CONTACT IS: