



® R&M Materials Handling, Inc
Springfield, Ohio USA
☎: 800 955-9967
www.rmhoist.com

LoadMate® Chain Hoist
LM1 Installation & Maintenance Manual

April 2005

LoadMate®

LM1 ELECTRIC CHAIN HOIST

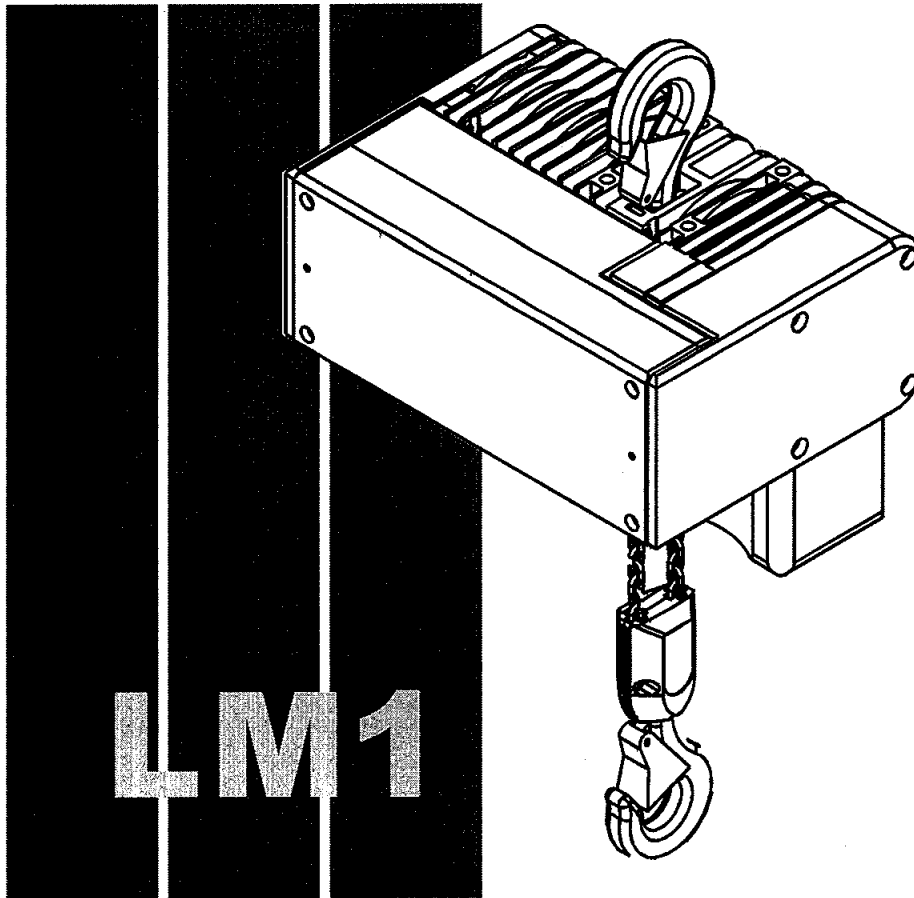

INSTALLATION & MAINTENANCE MANUAL

JOB NO.: _____

SERIAL NO.: _____

(RECORD HOIST SERIAL NUMBER FOR FUTURE REFERENCE)



7 PARTS ILLUSTRATION

7.1 Hoist Body

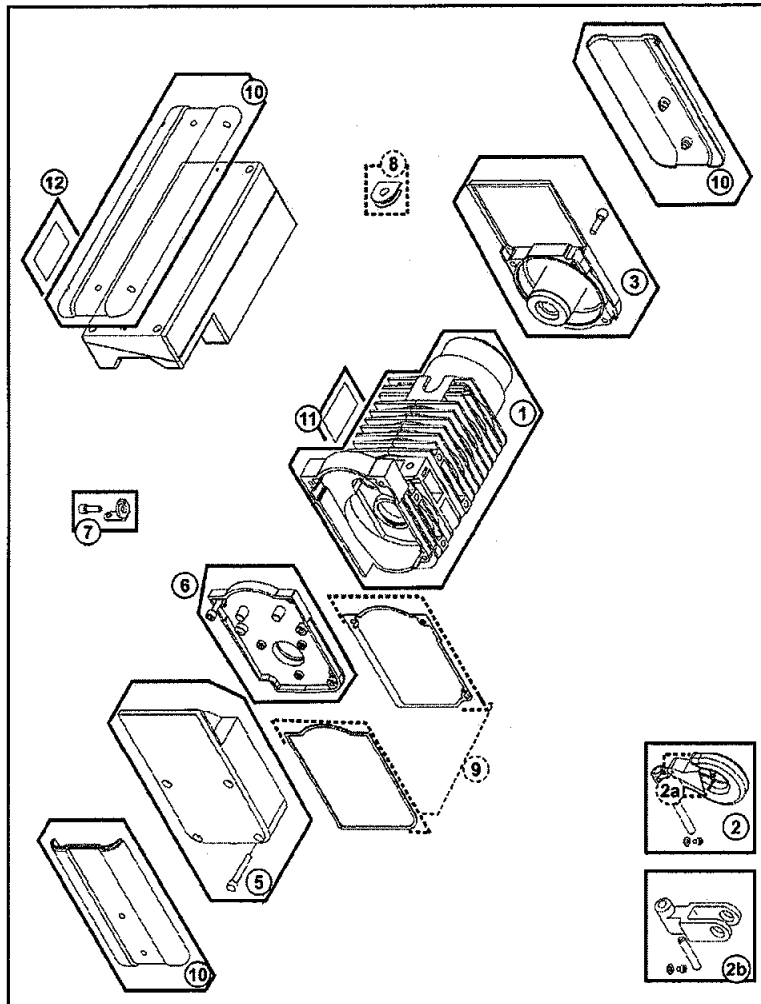



ITEM	PART NUMBER	DESCRIPTION	QTY PER
	52292290	TWO SPEED BODY & CONTROLS: 208/230V – 3 PHASE	1
	52292289	TWO SPEED BODY & CONTROLS: 460V – 3 PHASE	1
	52292291	TWO SPEED BODY & CONTROLS: 575V – 3 PHASE	1
	52315417	SINGLE SPEED BODY & CONTROLS: 115V – 1 PHASE	1
1	N/A	MACHINED HOIST BODY WITH STATOR	1
2	2218060	TOP HOOK SET	1
2a	2212016	TOP HOOK SAFETY LATCH – STEEL PLATE TYPE	1
2b	2218061	COUPLING SET	1
3	2218055	MOTOR END CAP ASSEMBLY	1
5	2218056	BRAKE COVER SET	1
6	2218057	GEAR COVER / FLANGE ASSEMBLY	
7	2218000	PUSH BUTTON ANCHOR BRACKET ASSEMBLY	1
8	2218004	POWER CABLE GUIDE	1
9	2218058	GASKET SET	1
10	2406879007	LM1 BRANDING SET	1
12a	2213309005	BODY CAPACITY STICKER - 1/8 TON	1
12b	2213309001	BODY CAPACITY STICKER - 1/4 TON	1
12c	2213309018	BODY CAPACITY STICKER - 125 KG	1
12d	2213309007	BODY CAPACITY STICKER – 250 KG	1
-	2213445002	ELECTRICAL HAZARD WARNING SIGN	1
-	2213445001	ELECTRICAL WIRING INFORMATION LABEL	1
-	52296703	2-FALL WARNING LABEL (2-FALL ONLY)	1



7.2 Helical Gear Mechanism & Brake

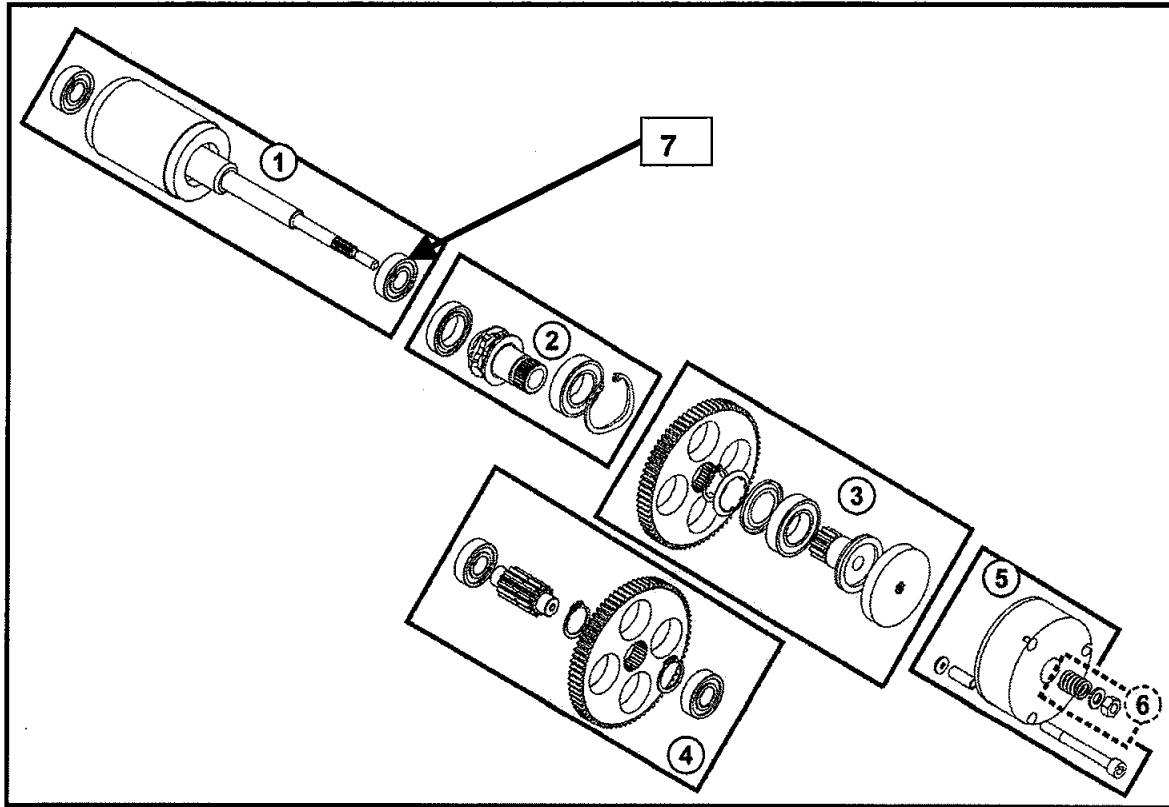

ITEM	PART NUMBER	DESCRIPTION	QTY PER
1a	2218040	ROTOR ASSEMBLY – 3 PHASE POWER SUPPLY	1
1b	52315094	ROTOR ASSEMBLY – 1 PHASE POWER SUPPLY	1
2	2218041	CHAIN SPROCKET ASSEMBLY	1
3	2218042	FRICTION DISC ASSEMBLY FOR SLIP CLUTCH	1
4	2218043	GEAR ASSEMBLY	1
5a	2218030	MOTOR BRAKE ASSY 190 VDC – 460 VAC	1
5b	2218031	MOTOR BRAKE ASSY 100 VDC – 115/208/230 VAC	1
5c	2218032	MOTOR BRAKE ASSY 230 VDC – 575 VAC	1
6	2218044	SLIP CLUTCH SRPING SET	1
7	52309505	BEARING SET (7 TOTAL PER SET)	1

7.3 Lifting Assembly

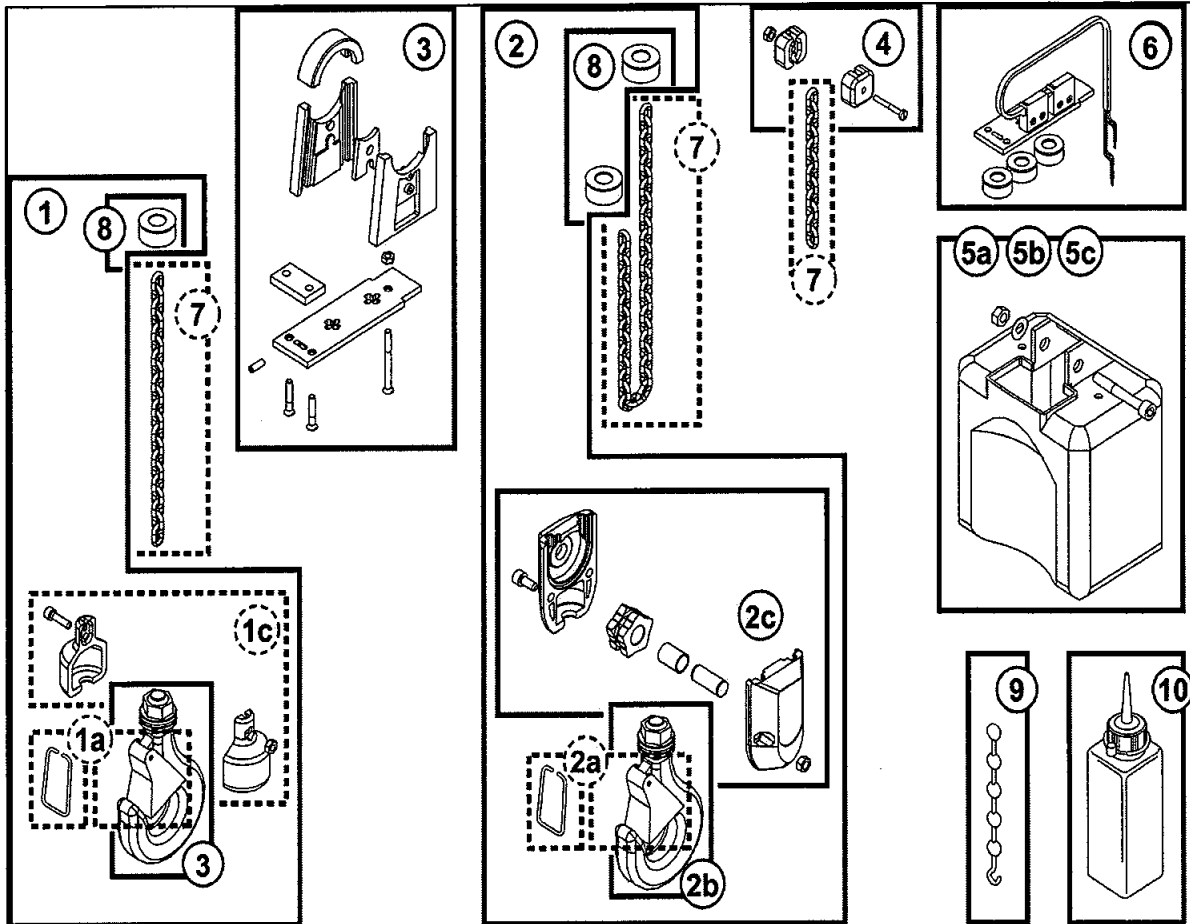



ITEM	PART NUMBER	DESCRIPTION	QTY PER
1	2218045	1-FALL LOAD BLOCK ASSEMBLY	1
1a	001512	1-FALL SAFETY LATCH – WIRE TYPE	1
1a	2212016	1-FALL SAFETY LATCH – STEEL PLATE	1
1b	2218046	1-FALL LOAD HOOK	1
1c	2218047	1-FALL LOAD BLOCK HALVES, PIN AND HARDWARE	-
1d	2213454001	1-FALL LOAD BLOCK CAPACITY STICKER – 1/8 TON	2
1d	2213454002	1-FALL LOAD BLOCK CAPACITY STICKER – 125 kg	2
2	2218048	2-FALL LOAD BLOCK ASSEMBLY	1
2a	001512	2-FALL SAFETY LATCH – WIRE TYPE	1
2a	2212016	2-FALL SAFETY LATCH – STEEL PLATE	1
2b	2218046	2-FALL LOAD HOOK	1
2c	2218085	2-FALL LOAD HOOK HALVES, SPROCKET, AXLE, AND HARDWARE	-
2d	2213308016	2-FALL CAPACITY STICKER – 125 kg	1
2d	2213308007	2-FALL CAPACITY STICKER – 250 kg	1
2d	2213308006	2-FALL CAPACITY STICKER – 1/8 TON	1
2d	2213308001	2-FALL CAPACITY STICKER – 1/4 TON	1
3	2218024	CHAIN GUIDE KIT	1
4	2218025	SLACK FALL STOP ASSEMBLY	1
5a	2218026	CHAIN CONTAINER & HARDWARE – 26FT (8m) MAX	1
5b	2218027	CHAIN CONTAINER & HARDWARE – 52FT (16m) MAX	1
5c	2218028	CHAIN CONTAINER & HARDWARE – 96FT (30m) MAX	1
6	2218029	UPPER / LOWER LIMIT SWITCH ASSEMBLY	1
7a	2218075	LOAD CHAIN – ZINC PLATED	N
7b	52288187	LOAD CHAIN – BLACK	N
7c	52288934	LOAD CHAIN – STAINLESS STEEL (CHECK CAPACITY LIMITS)	N
8a	2218076	RUBBER BUFFER (BUMPER) 1-FALL	2
8b	2218076	RUBBER BUFFER (BUMPER) 2-FALL	3
9	2218077	LOAD CHAIN INSERTION TOOL	1
10	9995008	LOAD CHAIN LUBRICANT	1

7.4 Control Panel Assembly – 3 Phase Power Supply

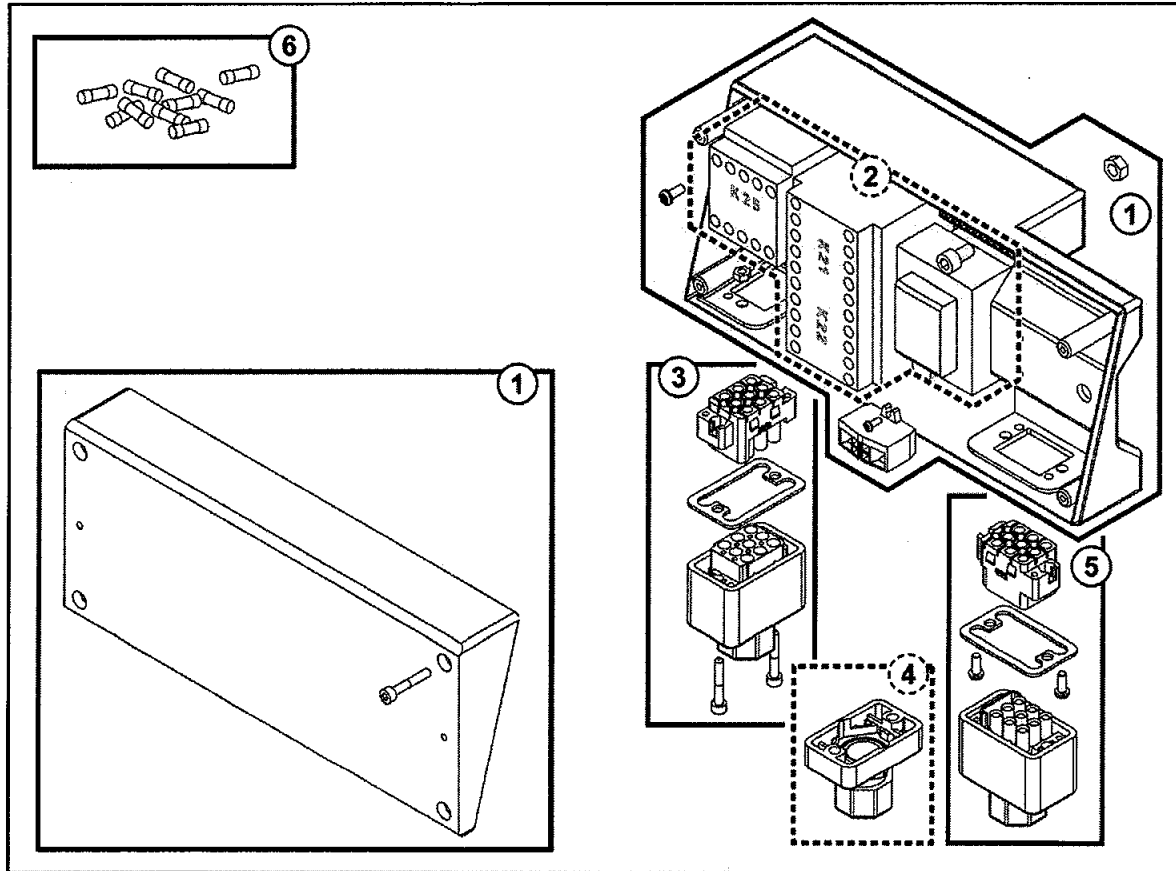

ITEM	PART NUMBER	DESCRIPTION	QTY PER
1	52308791	CONTROL BOX COVER SET	1
2a	2218095	PC BOARD 208/230VAC – TWO SPEED (115V CONTROL VOLTAGE)	1
2b	2218094	PC BOARD 460VAC – TWO SPEED (115V CONTROL VOLTAGE)	1
2c	2218096	PC BOARD 575VAC – TWO SPEED (115V CONTROL VOLTAGE)	1
3	2249982	POWER PLUG SET (OPTIONAL ON C01 HOIST)	1
4	2249947	POWER CABLE GLAND	1
5	2249945	X23 PUSH BUTTON PLUG SET FOR CONTROL BOX	1
6a	52314754	CONTROL CIRCUIT FUSES – 115V CONTROL VOLTAGE – SET OF 10	1
6b	2219988	CONTROL CIRCUIT FUSES – 48V CONTROL VOLTAGE – SET OF 10	1

7.5 Control Panel Assembly – 115 Volt 1-Phase Power Supply

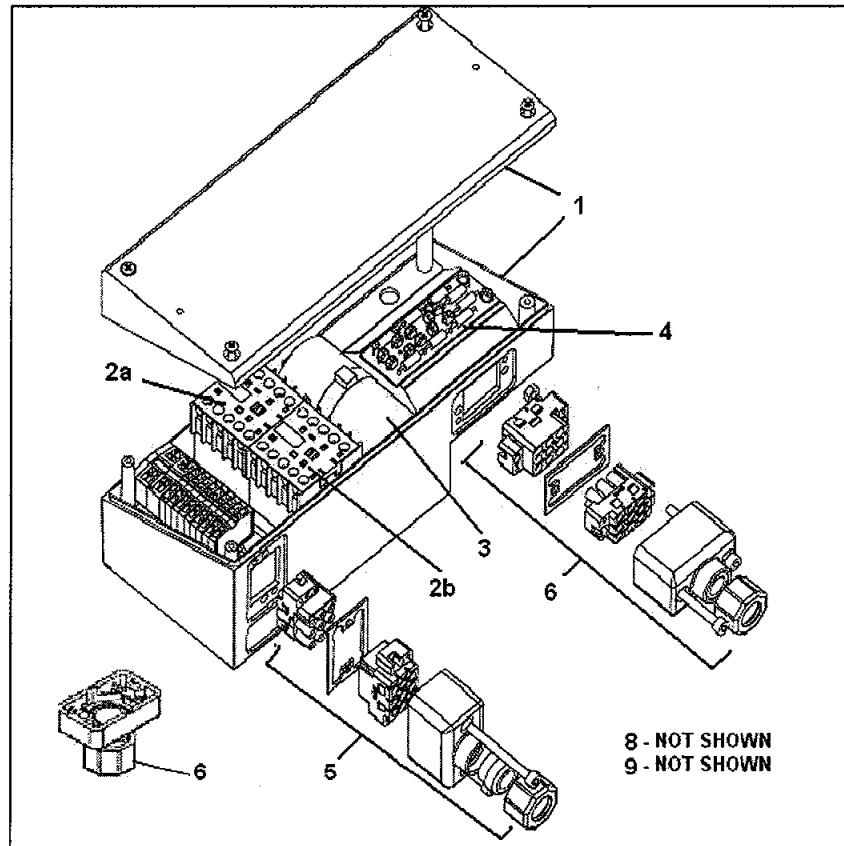

ITEM	PART NUMBER	DESCRIPTION	QTY
1	2218078	ELECTRICAL ENCLOSURE SET – BASE AND COVER	1
A	52314680	CONTROLS & ENCLOSURE ASSEMBLY – 1+2+3+4	1
2	52315603	CONTACTORS K21 or K22 – 115 VAC 1-PHASE	1
3	52315864	MOTOR CAPACITOR 115VAC 60Hz 1-PHASE MOTOR	1
4	52315863	MOTOR BRAKE RECTIFIER ASSY – 115 VAC 1-PHASE	1
5	2249982	POWER SUPPLY PLUG ASSEMBLY – OPTIONAL ON C01	1
6	2249947	POWER SUPPLY CABLE GLAND	1
7	2249945	X23 PUSH BUTTON PLUG ASSEMBLY ON CONTROL BOX	1
8	52315883	CONTROL FUSES – SET OF 10 – 115 VAC 1-PHASE	1
9	52281214	FUSE HOLDER	1



7.6 Push Button Assembly – Vertical Pairs of Buttons

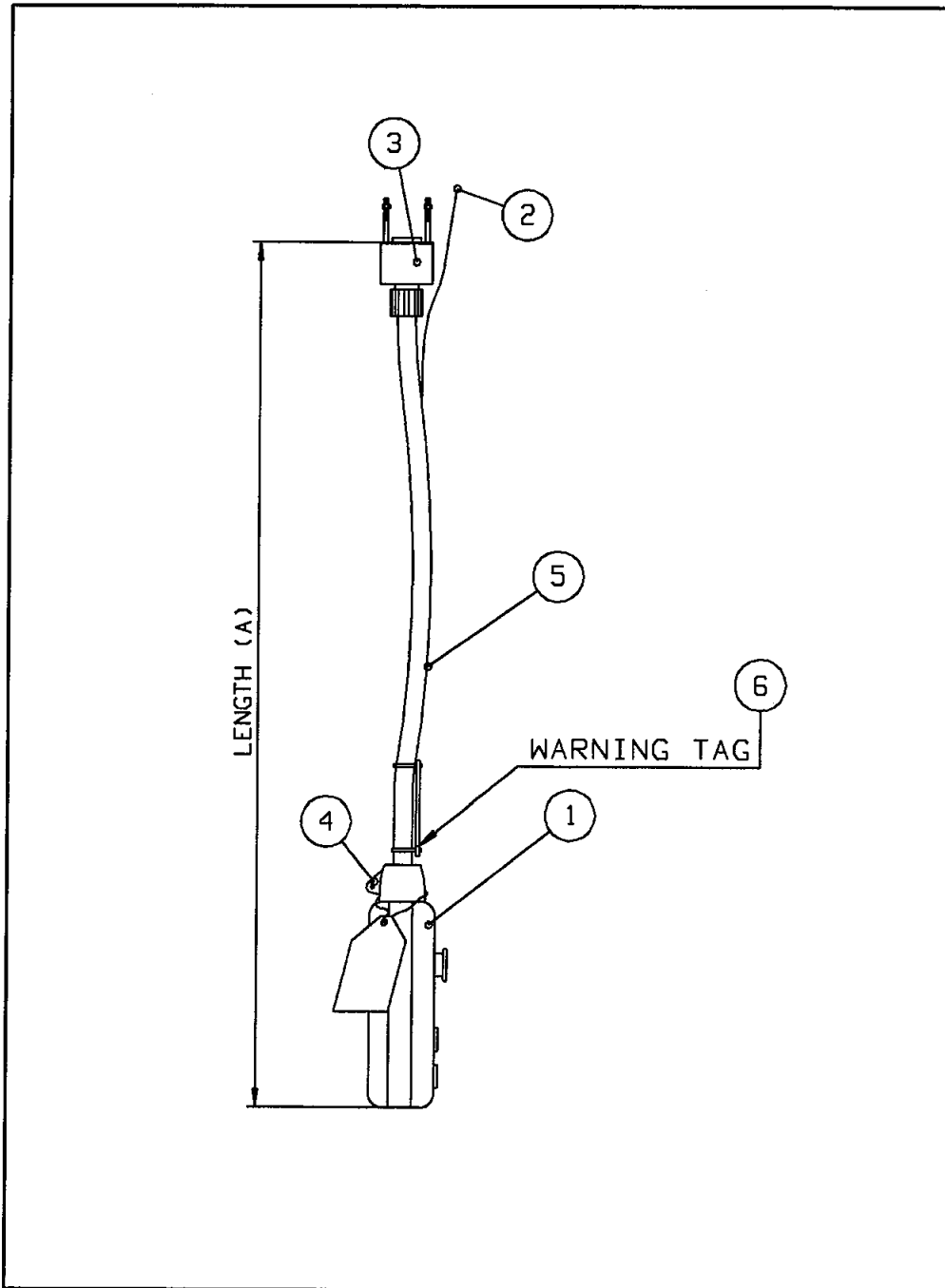



R&M®
Materials
Handling
Inc.
R&M Materials Handling, Inc
Springfield, Ohio USA
☎: 800 955-9967
www.rmhoist.com

LoadMate® Chain Hoist
LM1 Installation & Maintenance Manual

April 2005

ITEM	PART NUMBER	DESCRIPTION	QTY
-	2309673010	E-STOP, SINGLE SPEED HOIST – 10 FT P/B ASSEMBLY	1
-	2309673015	E-STOP, SINGLE SPEED HOIST – 15 FT P/B ASSEMBLY	1
-	2309673020	E-STOP, SINGLE SPEED HOIST – 20 FT P/B ASSEMBLY	1
-	2309674010	E-STOP, TWO SPEED HOIST – 10 FT P/B ASSEMBLY	1
-	2309674015	E-STOP, TWO SPEED HOIST – 15 FT P/B ASSEMBLY	1
-	2309674020	E-STOP, TWO SPEED HOIST – 20 FT P/B ASSEMBLY	1
1	2212932011	E-STOP, SS HOIST PUSHBUTTON ENCLOSURE ASSEMBLY	1
1	2212932012	E-STOP, TS HOIST PUSHBUTTON ENCLOSURE ASSEMBLY	1
2	2218000	UPPER SUSPENSION KIT	1
3	7285035	PLUG KIT	1
5	52292266	PUSH BUTTON ELECTRICAL CONTROL CABLE	1
6	2309414001	R&M PUSHBUTTON WARNING TAG - ENGLISH	1



7.7 Pushbutton Assembly – Horizontal Pairs of Buttons

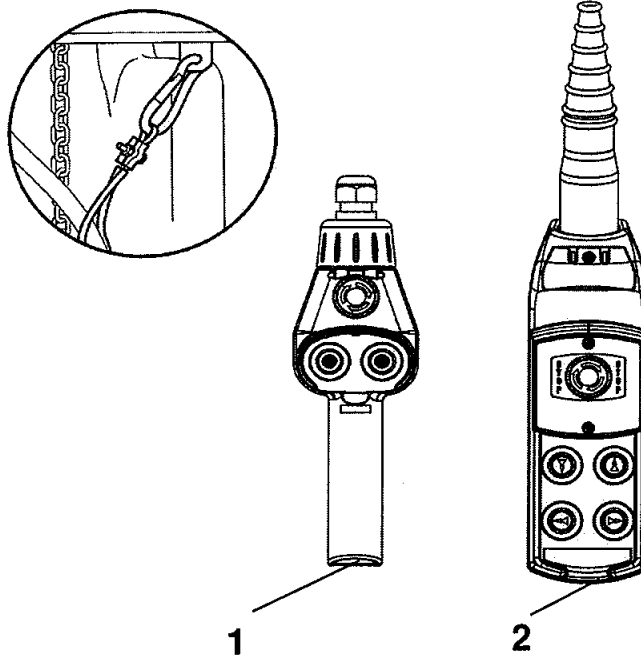

ITEM	PART NUMBER	DESCRIPTION	QTY
1	52301832	PISTOL GRIP P/B CONTROL ASSEMBLY – TWO SPEED	1
1	2309414001	R&M PUSHBUTTON WARNING TAG - ENGLISH	1