

R&M SPACEMASTER EX

LOW HEADROOM, 2 PART SINGLE
SX4 EX 021...L0

Bmini= 3 1/4"
Bmaxi= 19 1/4"
Bmaxi special= 27 1/8"

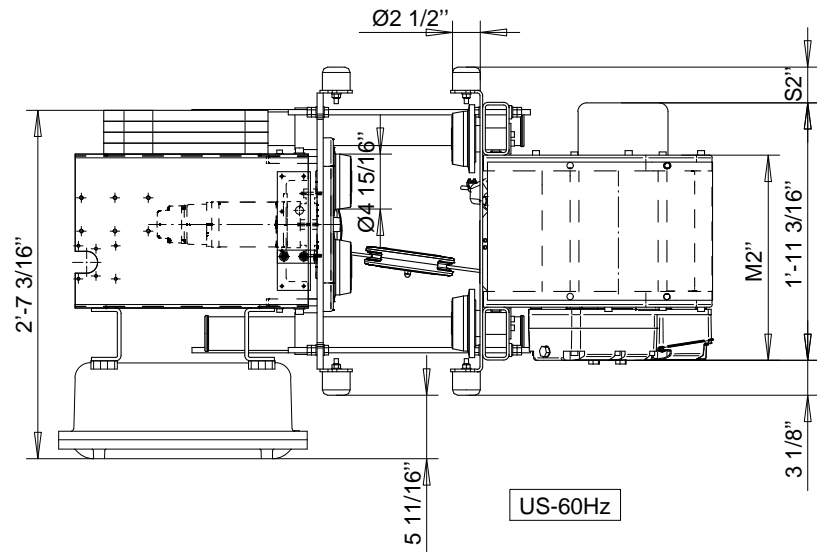
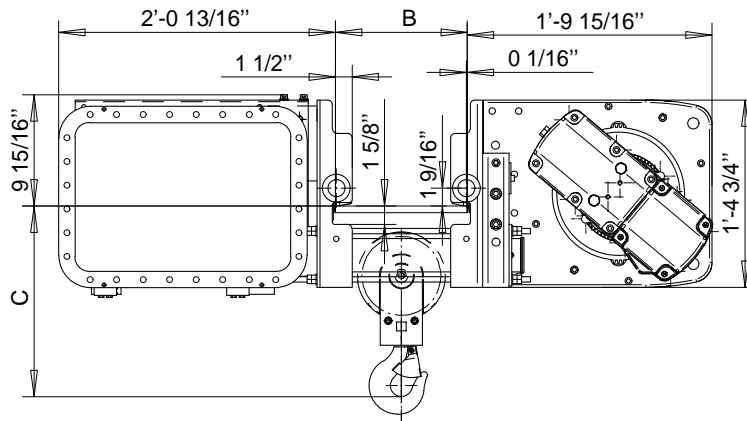
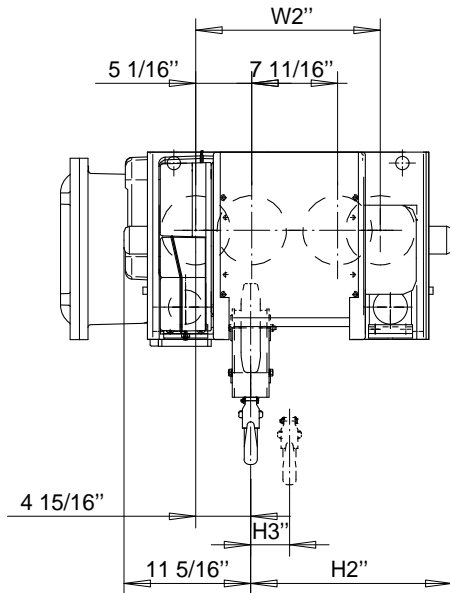

HEADROOM CHART

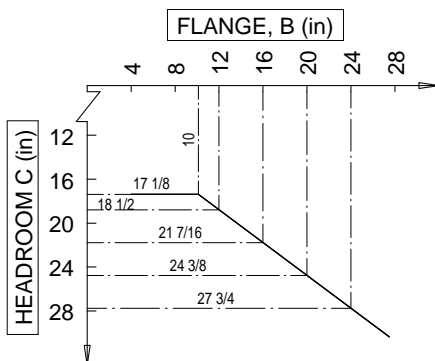

Load (TON)	Class ASME	Hoisting speed (fpm)
1 1/2	H4+	40/6.7
2	H4+	40/6.7
2 1/2	H4	40/6.7

HOL (ft-in)	Length code	M2 (in)	H2 (in)	H3 (in)	S2 (in)	W2 (in)	Weight (lb)
39'-4"	B	18 3/8	14 31/32	3 3/4	2	15 15/16	717
59'-0"	C	22 5/16	18 7/8	5 11/16	5 15/16	19 7/8	761
78'-8"	D	26 1/4	22 13/16	7 19/32	9 7/8	23 13/16	805