

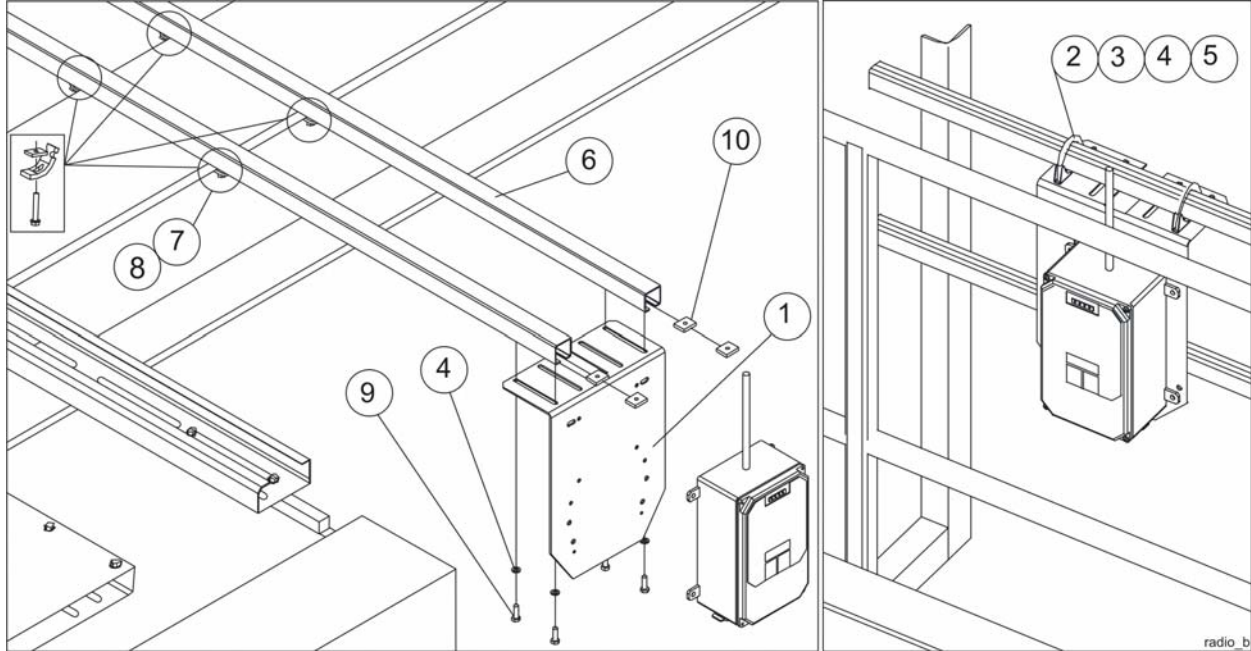

R&M Materials Handling, Inc.
 4501 Gateway Boulevard
 Springfield, Ohio 45502
 P.: (937) 328-5100
 FAX: (937) 325-5319

14 Radio assembly



Pos.	Name	Specification	Amount
1	Bracket	CQ-L128W280H378T3	1
2	Fastener	CQ-D42/85182306	2
3	Fastener	CQ-D51/85182309	2
4	Washer	DIN127-AB-A3G	4
5	Washer	DIN125-AB-A3G	4
6	Rail; C-Rail	KC-020276-1800	2
7	Beam Clip	KC-020181-08	4
8	Beam Clip	KC-020180-08X36	4
9	Screw	DIN933-MBX25-8.8-A3G	4
10	Fixing Part	CQ-W25T6L30	4

- When assembling radio to the crane without a service platform it can be fixed to two C-rail supports next to bridge panel in single girder crane and to bridge panel mounting rail next to bridge panel in double girder crane.
- Otherwise radio will be fixed to the service platforms hand rail.
- Use rubber bushings for mounting the radio. They are included in radios scope of supply.