

# GES5 - F06 BRIDGE DRIVE

QX.GES5DP02A1

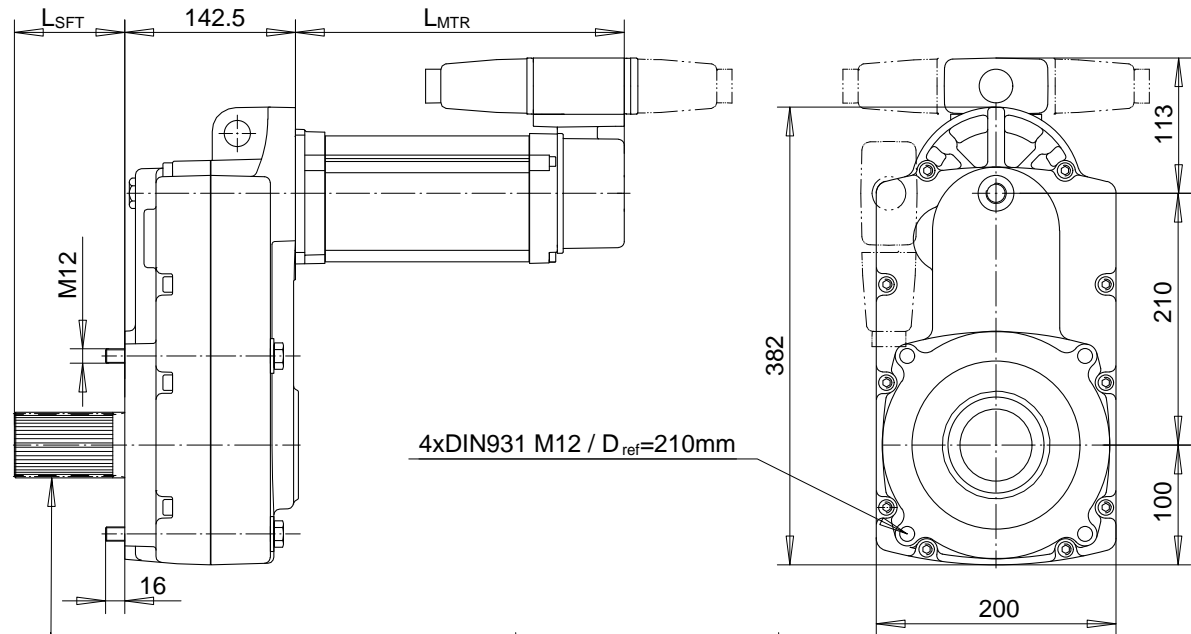

DIN5480-W55x2x30x26x8f	GES5..PS1-	L <sub>SFT</sub> =92
DIN5480-W45x2x30x21x8f	GES5..PS2-	L <sub>SFT</sub> =83

MAXIMUM TRAVELLING SPEED (*)			3000 rpm MOTOR [m/min] (**)			3600 rpm MOTOR [fpm] (**)		
MACHINERY TYPE	RATIO	T 2max (***)	Dw=500	Dw=320	Dw=250	Dw=500	Dw=320	Dw=250
GES5B5PS.BOF06	114.3	2030 Nm	40	25	20	160	100	80
GES572PS.BOF06	70.66	1450 Nm	63	40	32	250	160	125

SUITABLE MF06 INVERTER MOTORS					
MOTOR TYPE	L MTR	P n	U/f	n s	T n
MF06LB200	275 mm	1.1 kW	3~400V/100 Hz	3000 rpm	3.8 Nm
MF06LB200	275 mm	1.1 kW	3~460V/120 Hz	3600 rpm	3.1 Nm
MF06LB100	275 mm	1.1 kW	3~400V/ 80 Hz	4800 rpm	2.3 Nm

(\*) SPEED IS CALCULATED WITH AN AVERAGE SLIP. ACTUAL SPEED DEPENDS ON LOAD, MOTOR AND INVERTER.

(\*\*) TRAVELLING SPEED WITH OTHER MOTOR SPEED THAN SHOWN ON TABLE CAN BE DERIVED FROM THE MOTOR SPEED DIFFERENCE, EG. WITH 4800 rpm MOTORS THE MAXIMUM SPEED IS THE TABLE SPEED MULTIPLIED BY 1.6 (=4800/3000).

(\*\*\*) MAXIMUM SECONDARY TORQUE WITH THE S1 SHAFT END (W55x2). WITH S2 SHAFT END (W45x2) THE TORQUE SHALL NOT EXCEED 1800 Nm.

## COMPONENTS - BRIDGE DRIVE

Dimensions are for reference in estimating only. Use of various modifications may affect overall dimensional outline. Where dimensions are critical, request certified drawings for construction. All dimensions are in millimeters unless otherwise noted.

Wt. kg (lb)	Chd	Appd	p_QX.GES5DP02A1 File
	2002-09-23 Date	QX.GES5DP02A1	
	R&M	R&M Materials Handling Inc.	
	MATERIALS HANDLING	4501 Gateway Blvd, Springfield	
	INC.	GES5-F06 DRIVE	Issue 3/2006