

RS11 END TRUCK

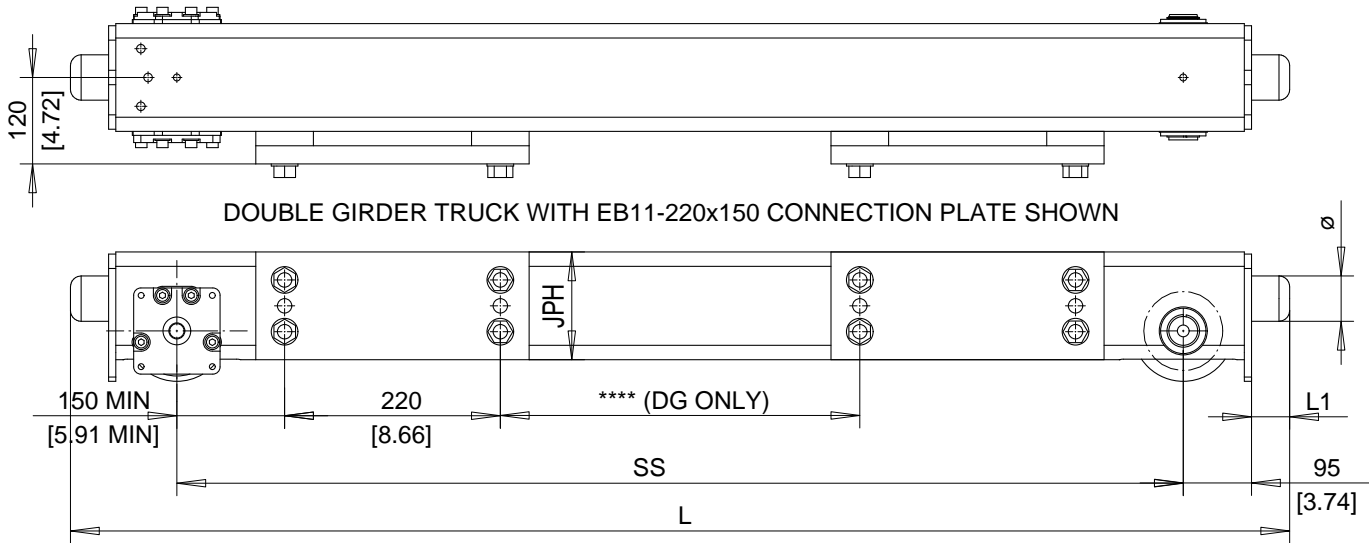

DOUBLE GIRDER TRUCK WITH EB11-220x150 CONNECTION PLATE SHOWN

BUMPER DIMENSIONS		
TYPE	L1	∅
	mm	mm
A	53	63
B	68	80
C	85	100
D	105	125

TREAD WIDTH RANGE
UU = 50mm [2"...70mm [2.75"]

COMPATIBLE WITH GES3 DRIVE

CONNECTION PLATE	HEIGHT JPH
EB11-220x150	150mm [5.91]
EB11-220x300	300mm [11.81]
EB11-220x480	480mm [18.90]

** The maximum wheel loads listed are only a guideline. The maximum values are based on assumption that the crane speed is 32m/min [105fpm], end truck duty is Fem 2m and the runway rail width is 50mm [2"]. If these conditions change, use QuoteMaster to help select the end truck.

Dimensions are for reference in estimating only. Use of various modifications may affect overall dimensional outline. Where dimensions are critical, request certified drawings for construction. All dimensions are in millimeters unless otherwise noted.

RS ENDTRUCK

SS mm (in)	H mm (in)	Max. dynamic whl load kN(kip)**		Wt. kg (lb)	Chd	Appd	p_QX.RS11 File
		Single girder	Double girder				
1400 (55.12)	150 (5.9)	26.0 (5.85)	44.0 (9.9)	110 (243)	2002-08-05 Date	QX.RS11	
1800 (70.87)	150 (5.9)	26.0 (5.85)	44.0 (9.9)	123 (271)	R&M	R&M Materials Handling Inc.	
2200 (86.61)	150 (5.9)	26.0 (5.85)	44.0 (9.9)	137 (302)	MATERIALS	4501 Gateway Blvd, Springfield	
2700 (106.3)	150 (5.9)	26.0 (5.85)	44.0 (9.9)	154 (340)	HANDLING INC.	RS11 END TRUCK	Issue 3/2006