

QX_RT25

Dimensions are for reference in estimating only. Use of various modifications may affect overall dimensional outline. Where dimensions are critical, request certified drawings for construction. All dimensions are in millimeters unless otherwise noted.

**The maximum wheel loads listed are only a guideline. The maximum values are based on assumption that the crane speed is 40 m/min (130 fpm), end truck duty is Fem 2m and the runway rail width is 80 mm (3.15"). If these conditions change, use QuoteMaster to help select the end truck.

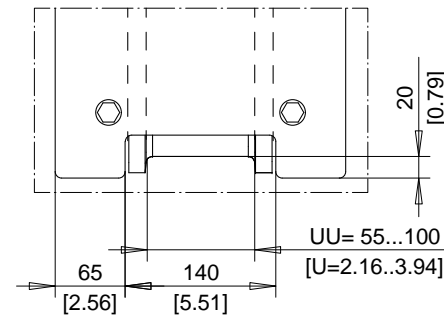

BUMPER DIMENSIONS		
TYPE	L1	ø
	mm	mm
B	68	80
C	85	100
D	105	125
E	150	100
F	190	125
H	160	160
I	200	200
M	125	125
P	240	160
S	300	200

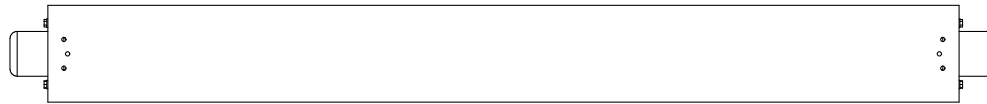

For joint plate details, refer to drawing:
 TOP JOINT PLATE TYPE K
 SIDE JOINT PLATE TYPE S
 End truck shown without joint plate.

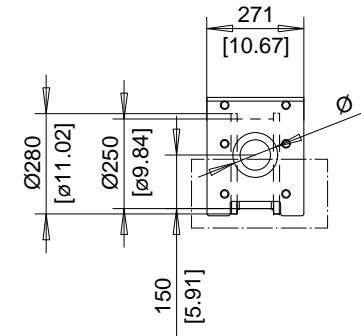
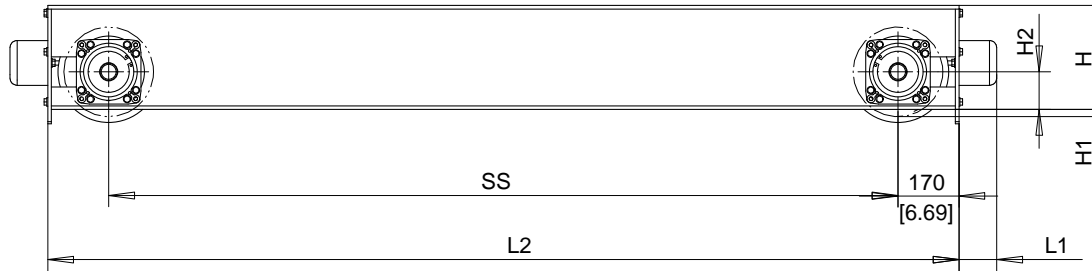
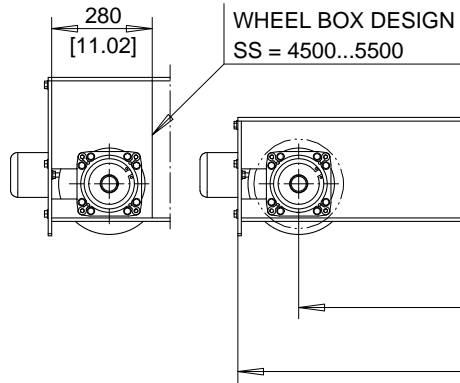

2200 mm WHEEL BASE END TRUCK SHOWN

COMPATIBLE WITH GES4/GES5 DRIVE

RT END TRUCK

SS mm [inch]	H mm [inch]	H1 mm [inch]	H2 mm [inch]	WEIGHT/TRK kg [lb]	MAX. DYN. WHL LOAD KN[KIPS]**	
					SINGLE GIRDER	DOUBLE GIRDER R=1200mm
2200 [86.61]	290 [11.42]	20 [0.79]	105 [4.13]	376 [829]	185 [40.88]	185 [40.88]
2700 [106.3]	290 [11.42]	20 [0.79]	105 [4.13]	426 [939]	152 [34.20]	185 [40.88]
3100 [122.1]	294 [11.57]	18 [0.71]	107 [4.21]	500 [1102]	149 [33.52]	185 [40.88]
3800 [149.6]	302 [11.89]	14 [0.55]	111 [4.37]	641 [1413]	150 [33.75]	185 [40.88]
4500 [177.2]	402 [15.83]	14 [0.55]	111 [4.37]	681 [1501]	156 [35.10]	185 [40.88]
5000 [196.9]	402 [15.83]	14 [0.55]	111 [4.37]	739 [1629]	140 [31.50]	183 [41.18]
5500 [216.5]	402 [15.83]	14 [0.55]	111 [4.37]	796 [1755]	128 [28.80]	161 [36.22]

Design	Chd	Appd	p_QX_RT25 File
XES / R&M	2002-09-19	QX_RT25	
Dept	Date	R&M Materials Handling Inc.	
R&M MATERIALS HANDLING INC.	4501 Gateway Blvd, Springfield		
	RT25 END TRUCK		
			Issue 3/2006