

QX.RT32B

Dimensions are for reference in estimating only. Use of various modifications may affect overall dimensional outline. Where dimensions are critical, request certified drawings for construction. All dimensions are in millimeters unless otherwise noted.

\*\*The maximum wheel loads listed are only a guideline. The maximum values are based on assumption that the crane speed is 40 m/min (130 fpm), end truck duty is Fem 2m and the runway rail width is 80 mm (3.15"). If these conditions change, use QuoteMaster to help select the end truck.

BUMPER DIMENSIONS		
TYPE	L1	ø
	mm	mm
B	68	80
C	85	100
D	105	125
E	150	100
F	190	125
H	160	160
I	200	200
M	125	125
P	240	160
S	300	200

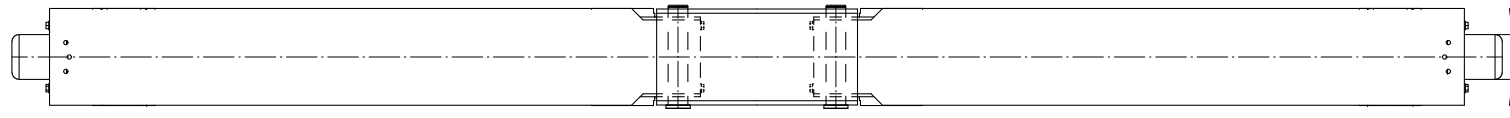
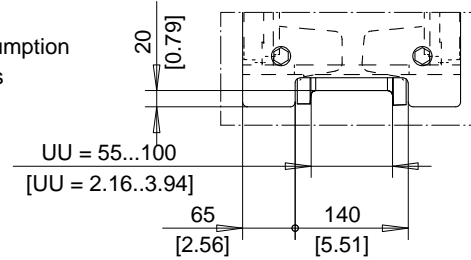

For joint plate details, refer to drawing:  
 TOP JOINT PLATE TYPE K  
 SIDE JOINT PLATE TYPE S  
 End truck shown without joint plate.

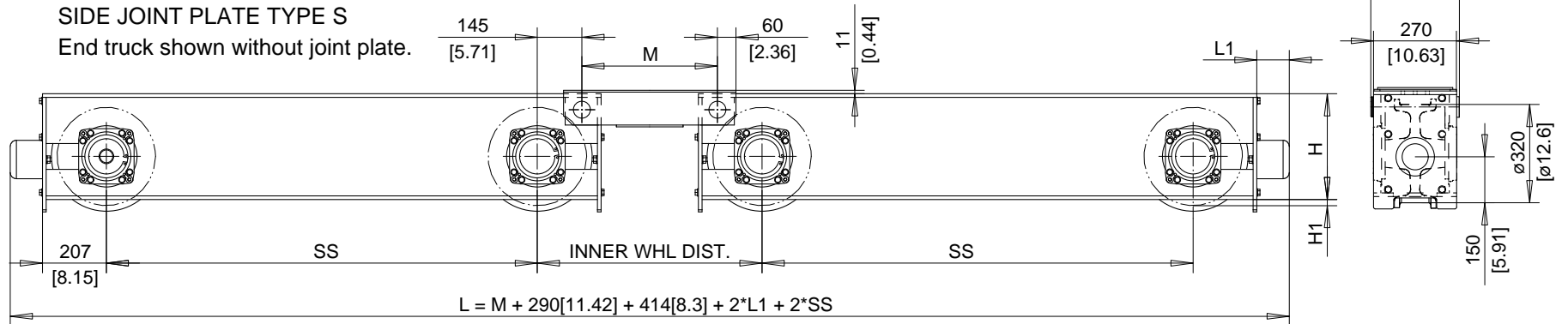

TOTAL WGT = WGT/TRK\*2 + M\*57 kg/m[3.2 lb/in]

TOTAL WGT IS FOR ONE-HALF SET FOR CRANE

1400 mm WHEEL BASE END TRUCK SHOWN

COMPATIBLE WITH GES4/GES5 DRIVE

### QX CRANE COMPONENT - RT END TRUCK

SS mm [inch]	H mm [inch]	H1 mm [inch]	Max. dynamic whl load kN(kip)**		WGT/TRK kg [lbs]	Design	Chd	Appd	p_QX.RT32B File
			Single girder	Double girder			2002-10-24		
1400 [55.12]	344 [13.54]	20 [0.79]	----	225 [50.6]	406 [895]				QX.RT32B
1600 [63]	344 [13.54]	20 [0.79]	----	225 [50.6]	433 [954]				R&M MATERIAL HANDLING, INC
1800 [70.9]	344 [13.54]	20 [0.79]	----	225 [50.6]	459 [1012]				SPRINGFIELD, OH USA
2000 [78.7]	344 [13.54]	20 [0.79]	----	225 [50.6]	486 [1071]				RT32B END TRUCK

Print copy

R&M  
MATERIALS  
HANDLING  
INC.

RT32B END TRUCK

Issue  
3/2006