

TOP JOINT PLATE TYPE P

FOR RT09, RT11, RT14 END TRUCKS
DG TRUCK SHOWN

QX.JPT_P

JOINT PLATE DIMENSIONS & WEIGHT			
VARIABLE	JOINT PLATE CODE		
	P3	P4	P6
JPL mm [in]	360 [14.17]	410 [16.41]	600 [23.62]
B mm [in]	310 [12.20]	350 [13.78]	550 [21.65]
Wgt kg [lb]	6 [13.2]	9 [19.8]	13 [28.7]

B = MAXIMUM FLANGE WIDTH

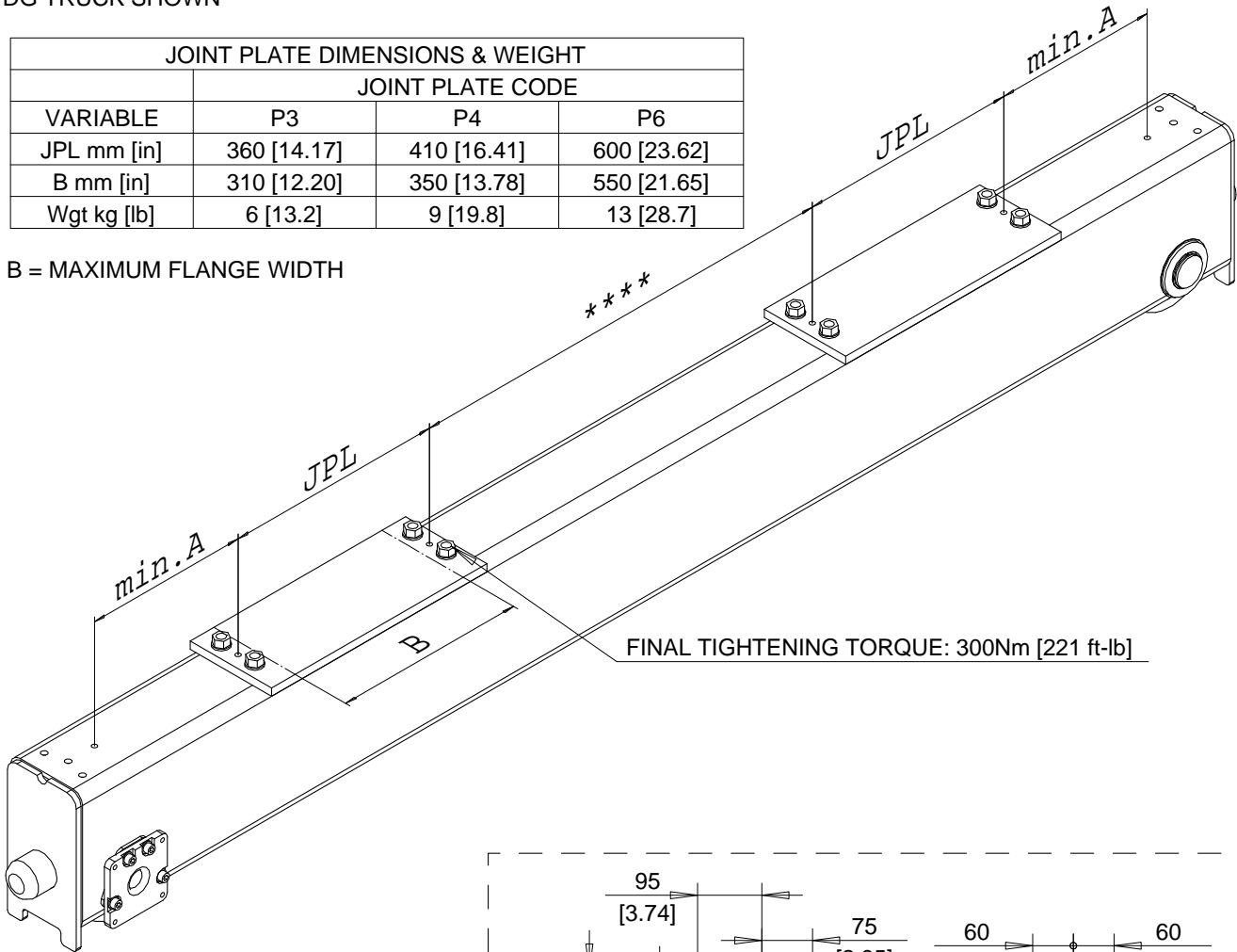

min A DIMENSION mm [in]	
TRUCK	min. A
RT09	100 [4]
RT11	110 [4.3]
RT14	125 [4.9]

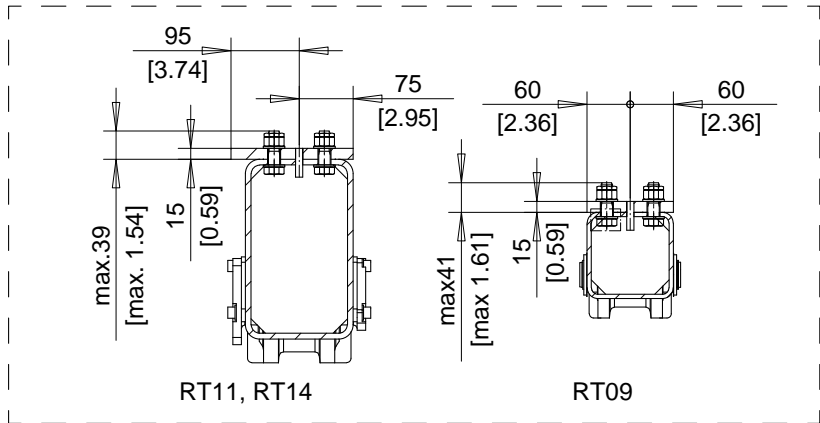

Dimensions are for reference in estimating only. Use of various modifications may affect overall dimensional outline. Where dimensions are critical, request certified drawings for construction. All dimensions are in millimeters unless otherwise noted.

MAXIMUM *** DIMENSION mm [in] (DOUBLE GIRDER ONLY)								
	RT09	RT11	RT11	RT14	RT14	Chd	Appd	p_QX.JPT_P File
SS mm [in]	P3	P4	P6	P4	P6	2002-08-05 Date	QX.JPT_P	
1400 [55.12]	480 [18.9]	380 [14.96]	----	350 [13.78]	----		R&M Materials Handling Inc.	
1800 [70.87]	880 [34.65]	780 [30.71]	380 [14.96]	750 [29.53]	350 [13.78]	R&M	4501 Gateway Blvd, Springfield	
2200 [86.61]	1280 [50.39]	1180 [46.46]	780 [30.71]	1150 [45.28]	750 [29.53]	MATERIALS		
2700 [106.3]	----	1680 [66.14]	1280 [50.39]	1650 [64.96]	1250 [49.21]	HANDLING	JOINT PLATE TYPE P	
3100 [122.05]	----	----	----	2050 [80.71]	1650 [64.96]	INC.		
3800 [149.6]	----	----	----	2750 [108.3]	2350 [92.52]			3/2006