

RSN09 END TRUCK

For single and double girder cranes

SI-60Hz

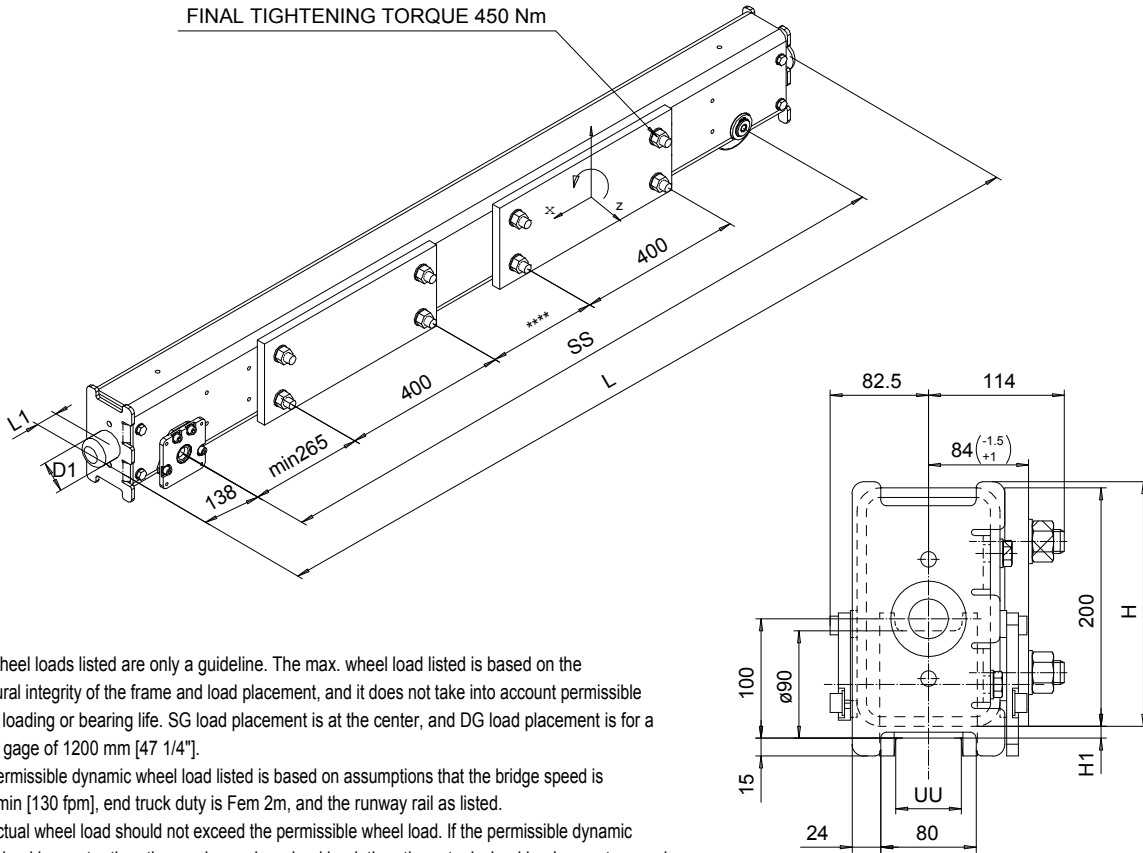

The wheel loads listed are only a guideline. The max. wheel load listed is based on the structural integrity of the frame and load placement, and it does not take into account permissible wheel loading or bearing life. SG load placement is at the center, and DG load placement is for a trolley gage of 1200 mm [47 1/4"].

The permissible dynamic wheel load listed is based on assumptions that the bridge speed is 40 m/min [130 fpm], end truck duty is Fern 2m, and the runway rail as listed.

The actual wheel load should not exceed the permissible wheel load. If the permissible dynamic wheel load is greater than the maximum dyn wheel load, then the actual wheel load cannot exceed maximum dyn wheel load.

Dynamic wheel = 1.15 x static wheel load

SS	H	H1	SG		DG		Permissible dyn wheel load		
			WT	Max dyn whl load	WT	Max dyn whl load	ASCE 30	ASCE 40	2" SQ BAR
[mm]	[mm]	[mm]	[kg]	[kN]	[kg]	[kN]	[kN]	[kN]	[kN]
1250	205	10	86	28	-	-	21.5	24.7	31.9
1600	205	10	99	28	116	28	21.5	24.7	31.9
2000	205	10	113	28	130	28	21.5	24.7	31.9
2500	205	10	132	28	149	28	21.5	24.7	31.9

$$L = SS + 276 + 2 \cdot L1$$

Available only with ductile iron wheel.

UU=50...70

RSN09 end truck is compatible with the GES3 gear motor and can be equipped with a second gear motor.

If the crane speed is faster, duty group is more severe, or the actual runway rail is narrower, then the max. allowable dynamic wheel load must be recalculated.

Suitable buffers		
Code	D1 [mm]	L1 [mm]
A	63	53
B	80	68
C	100	85
A, B, C: Rubber		

ETVPH Design 2007-01-03 Date		ETVPH Chd Appd Ref Drawing		EBN09	
SLBQDOCV Owner Dept		END CARRIAGE			
EBN09		EBN09		1 of 4 Folder EBN09	
		R&M MATERIALS HANDLING, INC. HOIST & CRANE PRODUCTS SPRINGFIELD, OHIO		Issue 3/2011	
This document is the absolute property of R&M Materials Handling, Inc. This document must not be copied without the written permission of R&M Materials Handling, Inc. The contents thereof must not be disclosed to a third party nor be used for any unauthorized purpose. Contravention will be prosecuted.		D004769-A			