

# RSN11 END TRUCK

For single and double girder cranes

SI-50/60Hz

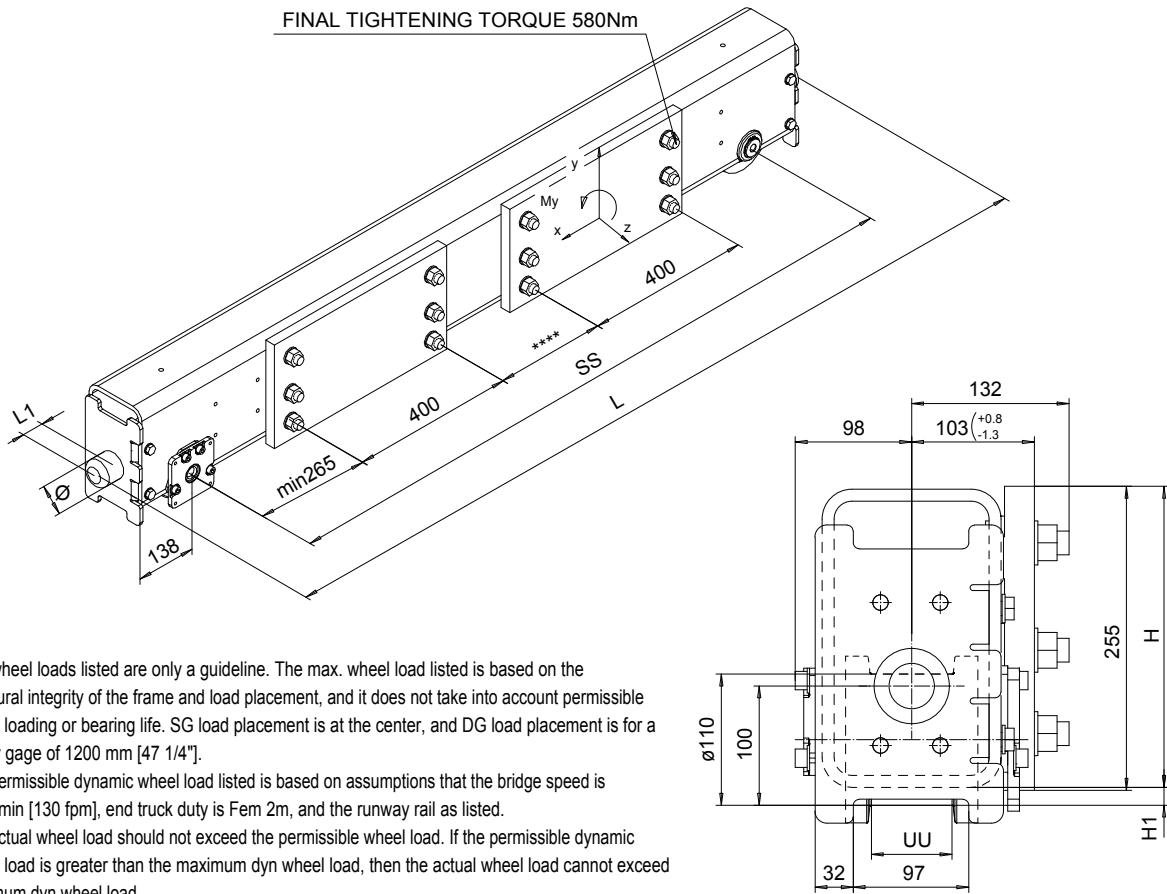

The wheel loads listed are only a guideline. The max. wheel load listed is based on the structural integrity of the frame and load placement, and it does not take into account permissible wheel loading or bearing life. SG load placement is at the center, and DG load placement is for a trolley gage of 1200 mm [47 1/4"].

The permissible dynamic wheel load listed is based on assumptions that the bridge speed is 40 m/min [130 fpm], end truck duty is Fem 2m, and the runway rail as listed.

The actual wheel load should not exceed the permissible wheel load. If the permissible dynamic wheel load is greater than the maximum dyn wheel load, then the actual wheel load cannot exceed maximum dyn wheel load.

Dynamic wheel = 1.15 x static wheel load

SS	H	H1	WT	SG		DG		Permissible dyn wheel load		
				Max dyn whl load	WT	Max dyn whl load	ASCE 30	ASCE 40	2" SQ BAR	
[mm]	[mm]	[mm]	[kg]	[kN]	[kg]	[kN]	[kN]	[kN]	[kN]	[kN]
1600	253	15	153	46	179	46	27.7	31.9	40.9	40.9
2000	253	15	176	46	202	46	27.7	31.9	40.9	40.9
2500	253	15	204	46	230	46	27.7	31.9	40.9	40.9
3150	253	15	241	46	267	46	27.7	31.9	40.9	40.9

$L = SS + 276 + 2 \cdot L1$

Available only with ductile iron wheel.

$UU = 52 \dots 87$

RSN11 end truck is compatible with the GES3 gear motor and can be equipped with a second gear motor.

If the crane speed is faster, the duty group is more severe, or the actual runway rail is narrower, then the maximum allowable dynamic wheel load must be re-evaluated.

Suitable buffers		
Code	D1 [mm]	L1 [mm]
A	63	53
B	80	68
C	100	85
K	80	80
G	100	100
E	100	150
A, B, C: Rubber		
K, G, E: Polyurethane		

<table border="1"> <tr> <td>1</td> <td></td> <td>2007-03-27</td> <td>ETVPH</td> <td></td> </tr> <tr> <td>Rev</td> <td>Explanation</td> <td>Date</td> <td>Drawn by</td> <td>Checked by</td> </tr> </table>				1		2007-03-27	ETVPH		Rev	Explanation	Date	Drawn by	Checked by	<table border="1"> <tr> <td>ETVPH</td> <td>ETVPH</td> <td></td> <td></td> <td>EBN11</td> </tr> <tr> <td>Design</td> <td>Chd</td> <td>Appd</td> <td>Ref Drawing</td> <td></td> </tr> <tr> <td>2007-03-27</td> <td></td> <td></td> <td></td> <td></td> </tr> <tr> <td>Date</td> <td></td> <td></td> <td></td> <td></td> </tr> <tr> <td>SLBQDOCV</td> <td></td> <td></td> <td></td> <td></td> </tr> <tr> <td>Owner</td> <td>Dept</td> <td></td> <td></td> <td></td> </tr> </table>	ETVPH	ETVPH			EBN11	Design	Chd	Appd	Ref Drawing		2007-03-27					Date					SLBQDOCV					Owner	Dept				<table border="1"> <tr> <td><b>END TRUCK</b></td> <td rowspan="2"> </td> </tr> <tr> <td><b>RSN11</b></td> </tr> <tr> <td>D004907-A</td> <td>                 1 of 4                  Folder:                  EBN11                  Issue:                  3/2011             </td> </tr> </table>	<b>END TRUCK</b>		<b>RSN11</b>	D004907-A	1 of 4 Folder: EBN11 Issue: 3/2011
1		2007-03-27	ETVPH																																															
Rev	Explanation	Date	Drawn by	Checked by																																														
ETVPH	ETVPH			EBN11																																														
Design	Chd	Appd	Ref Drawing																																															
2007-03-27																																																		
Date																																																		
SLBQDOCV																																																		
Owner	Dept																																																	
<b>END TRUCK</b>																																																		
<b>RSN11</b>																																																		
D004907-A	1 of 4 Folder: EBN11 Issue: 3/2011																																																	