

RTN11 END TRUCK

For single and double girder cranes

US-60Hz

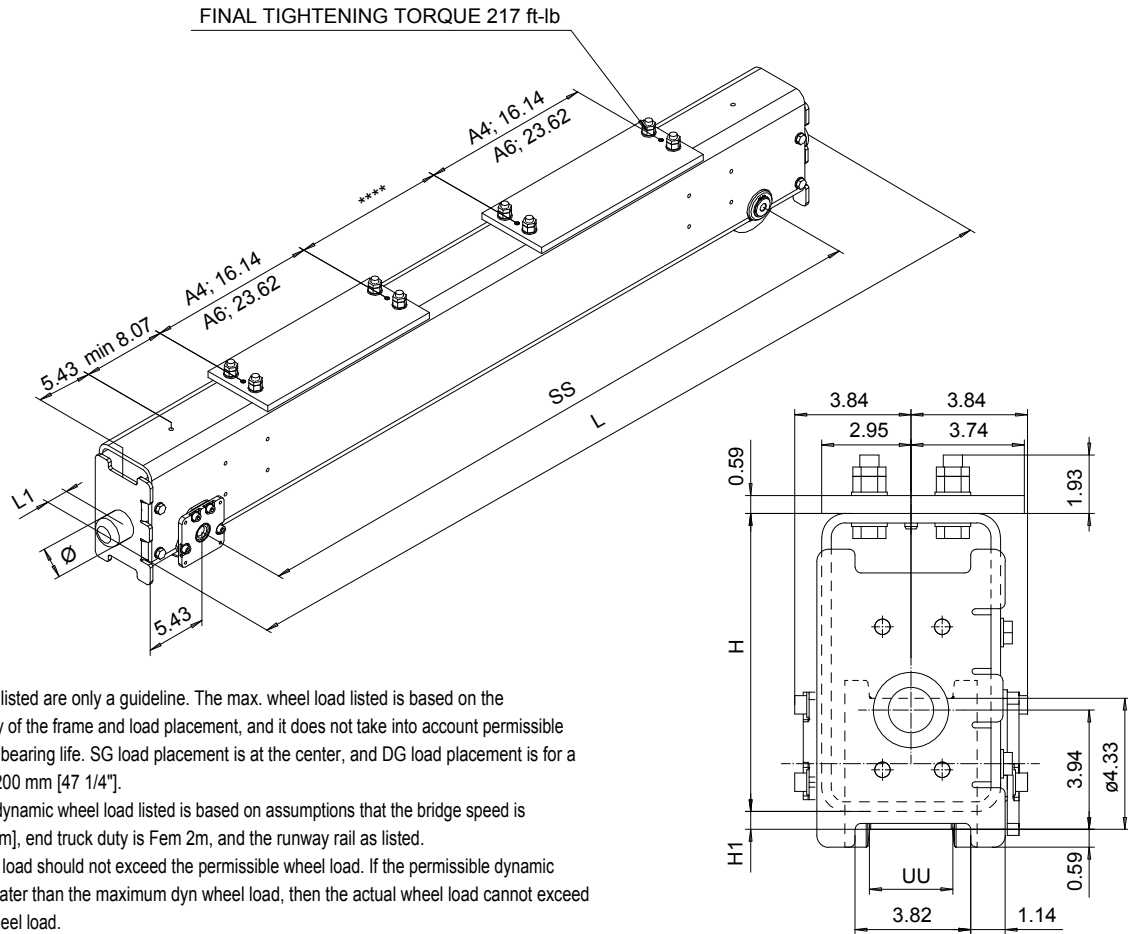

The wheel loads listed are only a guideline. The max. wheel load listed is based on the structural integrity of the frame and load placement, and it does not take into account permissible wheel loading or bearing life. SG load placement is at the center, and DG load placement is for a trolley gage of 1200 mm [47 1/4"].

The permissible dynamic wheel load listed is based on assumptions that the bridge speed is 40 m/min [130 fpm], end truck duty is Fem 2m, and the runway rail as listed.

The actual wheel load should not exceed the permissible wheel load. If the permissible dynamic wheel load is greater than the maximum dyn wheel load, then the actual wheel load cannot exceed maximum dyn wheel load.

Dynamic wheel = 1.15 x static wheel load

SS	H	H1	SG		DG		Permissible dyn wheel load		
			WT	Max dyn whl load	WT	Max dyn whl load	ASCE 30	ASCE 40	2" SQ BAR
[in] (mm)	[in]	[in]	[lb]	[lb]	[lb]	[lb]	[lb]	[lb]	[lb]
63 (1600)	9.84	0.59	258	10350	280	10350	6236	7167	9212
78.74 (2000)	9.84	0.59	300	10350	322	10350	6236	7167	9212
98.43 (2500)	9.84	0.59	351	10350	372	10350	6236	7167	9212
124 (3150)	9.84	0.59	417	10350	439	10350	6236	7167	9212

$L = SS + 10.87" + 2*L1$

Available only with ductile iron wheel.

$UU = 2.04" \dots 3.42"$

RTN11 end truck is compatible with the GES3 gear motor and can be equipped with a second gear motor.

If the crane speed is faster, the duty group is more severe, or the actual runway rail is narrower, then the maximum allowable dynamic wheel load must be re-evaluated.

Suitable buffers		
Code	D1 [in]	L1 [in]
A	2.48	2.09
B	3.15	2.68
C	3.94	3.35
K	3.15	3.15
G	3.94	3.94
E	3.94	5.91
A, B, C: Rubber		
K, G, E: Polyurethane		

ETTVPH Design 2007-03-29 Date				ETTVPH Chd Appd Ref Drawing		 1 of 4 Folder ECN11 Issue 3/2011
SLEQDOCV Owner Dept				END TRUCK RTN11		
Rev	Explanation	Date	Revised by	Checked by	D004918-A	

This document is the absolute property of R&M Materials Handling, Inc. This document must not be copied without the written permission of R&M Materials Handling, Inc. The contents thereof must not be disclosed to a third party nor be used for any unauthorized purpose. Contravention will be prosecuted.