

# GES4 - F07 BRIDGE DRIVE

QX.GES4DP02A1

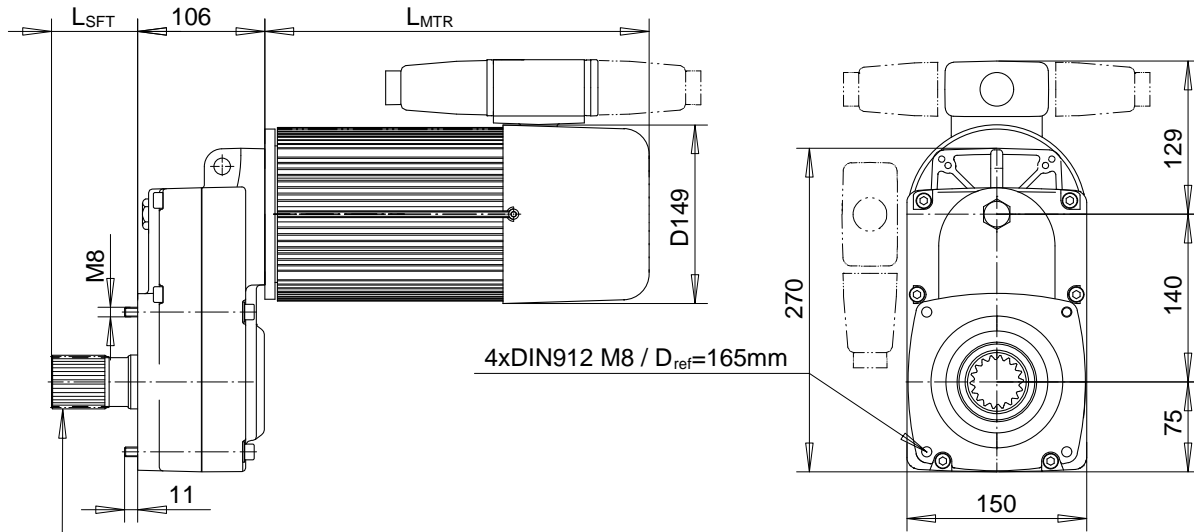

DIN5480-W45x2x30x21x8f	GES4..PS2-	L <sub>SFT</sub> =72
DIN5480-W30x1.5x30x18x8f	GES4..PS3-	L <sub>SFT</sub> =72

MAXIMUM TRAVELLING SPEED (*)			3000 rpm MOTOR [m/min]			3600 rpm MOTOR [fpm]		
MACHINERY TYPE	RATIO	T <sub>2</sub> max (**)	Dw=320	Dw=250	Dw=200	Dw=320	Dw=250	Dw=200
GES472PS.BOF07	72.80	570 Nm	40	32	25	160	125	100
GES463PS.BOF07	60.13	550 Nm	50	40	32	200	160	125

OPTIONAL MF07 POLE CHANGE MOTORS NOTE: 2-PHASE BRAKING REQUIRED					
MOTOR TYPE	L mtr	P n	U/f	n s	T n
MF07X-104	321 mm	0.75/0.18 kW	3~400V/50Hz	3000/750 rpm	2.6 Nm
MF07X-104	321 mm	0.90/0.20 kW	3~460V/60Hz	3600/900 rpm	2.6 Nm

\* SPEED IS CALCULATED WITH AN AVERAGE SLIP. ACTUAL SPEED DEPENDS ON LOAD AND MOTOR.

\*\* MAXIMUM SECONDARY TORQUE WITH THE S2 SHAFT END (W45x2). WITH S3 SHAFT END (W30x1.5) THE TORQUE SHALL NOT EXCEED 490Nm.

## COMPONENTS - BRIDGE DRIVE

Dimensions are for reference in estimating only. Use of various modifications may affect overall dimensional outline. Where dimensions are critical, request certified drawings for construction. All dimensions are in millimeters unless otherwise noted.

Wt.  
kg (lb)

Chd

Appd

p\_QX.GES4DP02A1  
File

2002-09-23  
Date

QX.GES4DP02A1

R&M Materials Handling Inc.

R&M  
MATERIALS  
HANDLING  
INC.

4501 Gateway Blvd, Springfield

**GES4-F07 DRIVE**

Issue  
3/2006