

Dimensions are for reference in estimating only. Use of various modifications may affect overall dimensional outline. Where dimensions are critical, request certified drawings for construction. All dimensions are in millimeters unless otherwise noted.

**For 2-falls, see outline drawing 2213417107 for dimensions

2213417106

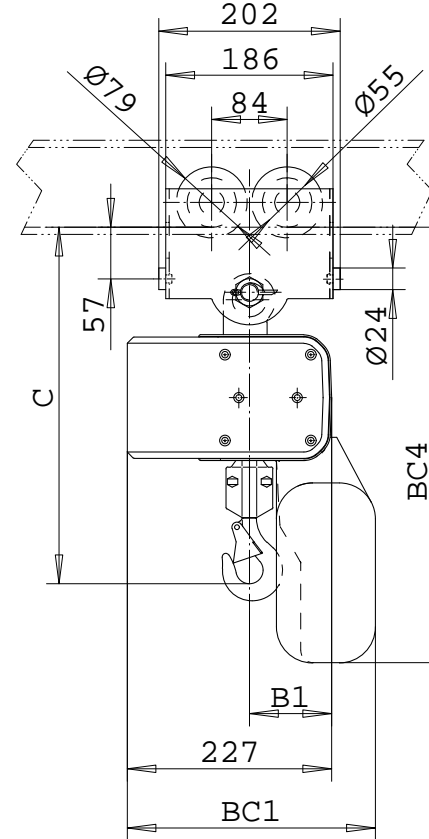
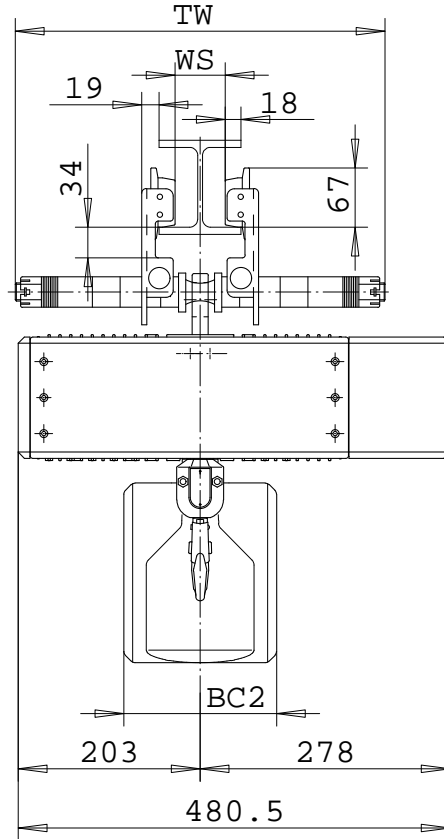

	C	B1	BC1				BC2				BC4			
LIFT			<8m	<16m	<30m	<50m	<8m	<16m	<30m	<50m	<8m	<16m	<30m	<50m
1 FALL	397	91	276	316	311	311	160	150	320	320	488	548	613	613

Minimum radius curve: 1 meter

SINGLE-PHASE CHAIN HOIST

LOAD MATE CHAIN HOIST MODEL NUMBER								TROLLEY DIMENSIONS						Chd	Appd	p_2213417106 File	
FR	CAP Kg	LIFT m	SUSP	1 SPEED m/MIN	2 SPEED m/MIN(4:1)	FALL	FLG CODE	FLG CODE	FLANGE RANGES	MAX. TD	MAX TW	MIN. WS	MAX FLG THK	2003-01-16 Date	2213417106	R&M Materials Handling Inc.	
LM05	250	3	PT	4.9S	---	1	1,2	1	50 - 200	**	303	14	29	R&M MATERIALS HANDLING INC.	4501 Gateway Blvd, Springfield	LM05 PT HOIST	
LM05	500	3	PT	4.9S	---	1	1,2	2	188 - 310	**	411	152	29				Issue
									**								02/2007