

Dimensions are for reference in estimating only. Use of various modifications may affect overall dimensional outline. Where dimensions are critical, request certified drawings for construction. All dimensions are in millimeters unless otherwise noted.

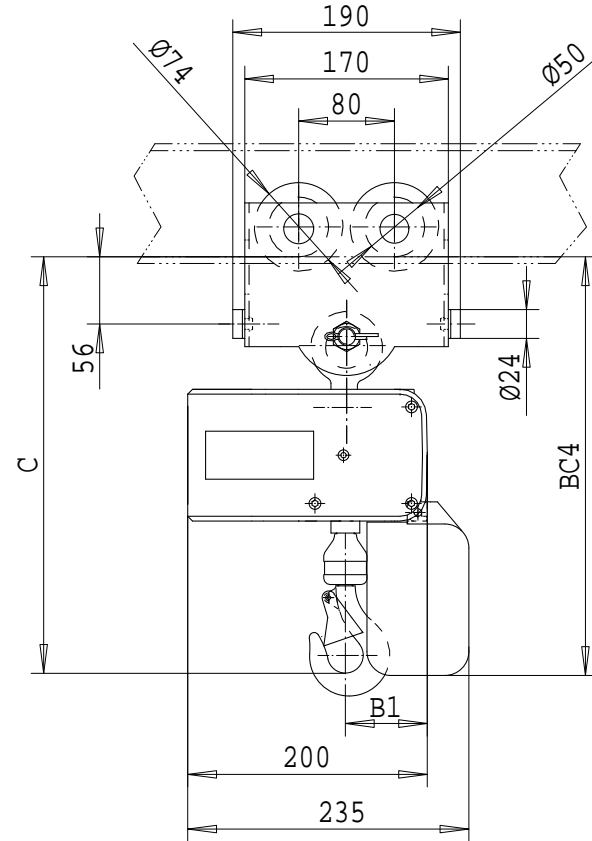
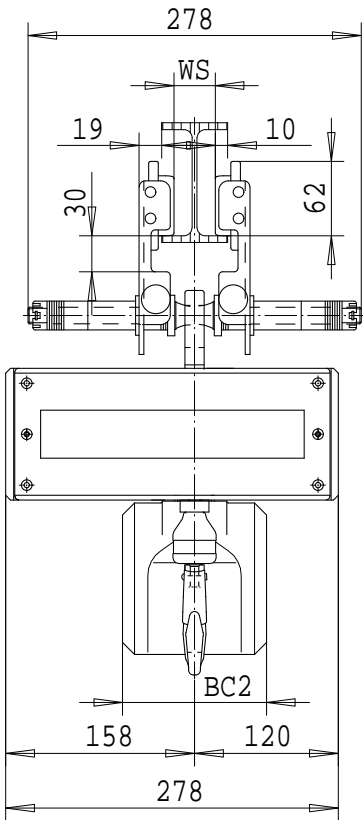

	C	B1	BC2			BC4		
LIFT			<8m	<16m	<30m	<8m	<16m	<30m
1 FALL	350	68	120	130	130	351	413	498

Minimum radius curve: 1 meter

SINGLE-PHASE CHAIN HOIST

LOAD MATE CHAIN HOIST MODEL NUMBER								TROLLEY DIMENSIONS						Chd	Appd	p_2213417105 File
FR	CAP Kg	LFT m	SUSP	1 SPEED m/MIN	2 SPEED m/MIN(4:1)	FALL	FLG CODE	FLG CODE	FLANGE RANGES	MAX. TD	MAX TW	MIN. WS	MAX FLG THK	2003-01-15 Date	2213417105	
LM1	125	3	PT	4.9S	---	1	1	1	50 - 202	**	**	30	25	R&M	R&M Materials Handling Inc.	
									**					MATERIALS	4501 Gateway Blvd, Springfield	
														HANDLING	LM1 PT HOIST	
														INC.	Issue	02/2007

2213417105