

Dimensions are for reference in estimating only. Use of various modifications may affect overall dimensional outline. Where dimensions are critical, request certified drawings for construction. All dimensions are in inches unless otherwise noted.

SINGLE-PHASE CHAIN HOIST

2213417110

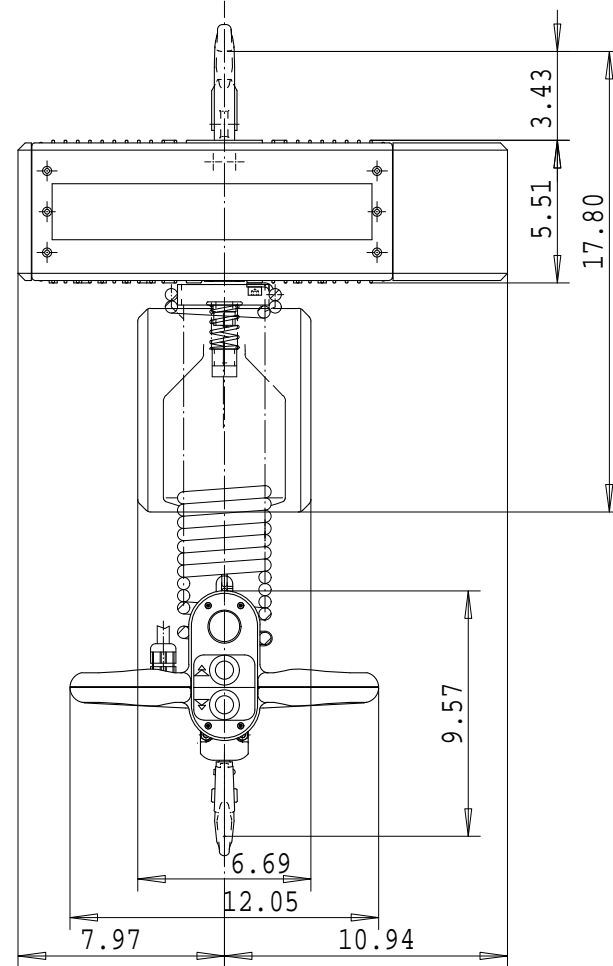
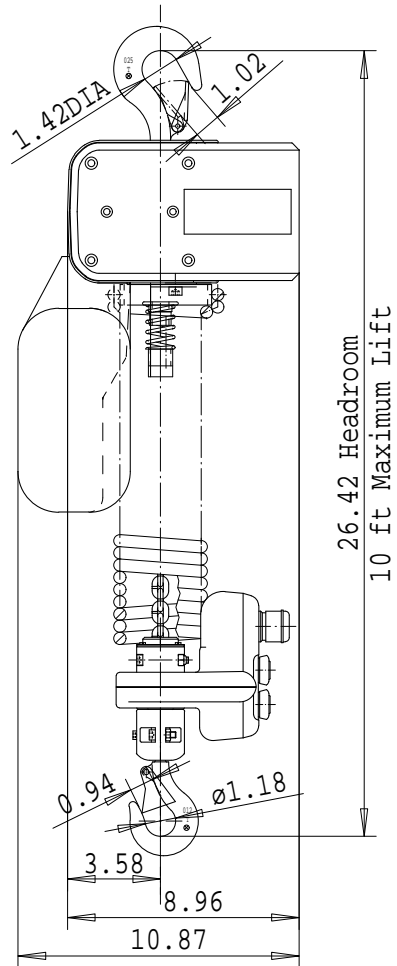

Note: Digichain option - available only for single fall

LOAD MATE CHAIN HOIST MODEL NUMBER							TROLLEY DIMENSIONS							Chd	Appd	p_2213417110 File
FR	CAP TON	LFT FT	SUSP	1 SPEED FPM	2 SPEED FPM(4:1)	FALL	FLG CODE	FLG CODE	FLANGE RANGES	MAX. TD	MAX TW	MIN. WS	MAX FLG THK	2003-03-31 Date	2213417110	
LM05	1/4	10	TH	16S	---	1	---	---	---	---	---	---	---		R&M Materials Handling Inc.	
LM05	1/2	10	TH	16S	---	1	---								4501 Gateway Blvd, Springfield	
															LM05 DIGICHAIN 1PH	Issue 02/2007