

Dimensions are for reference in estimating only. Use of various modifications may affect overall dimensional outline. Where dimensions are critical, request certified drawings for construction. All dimensions are in inches unless otherwise noted.

SINGLE-PHASE CHAIN HOIST

2213417109

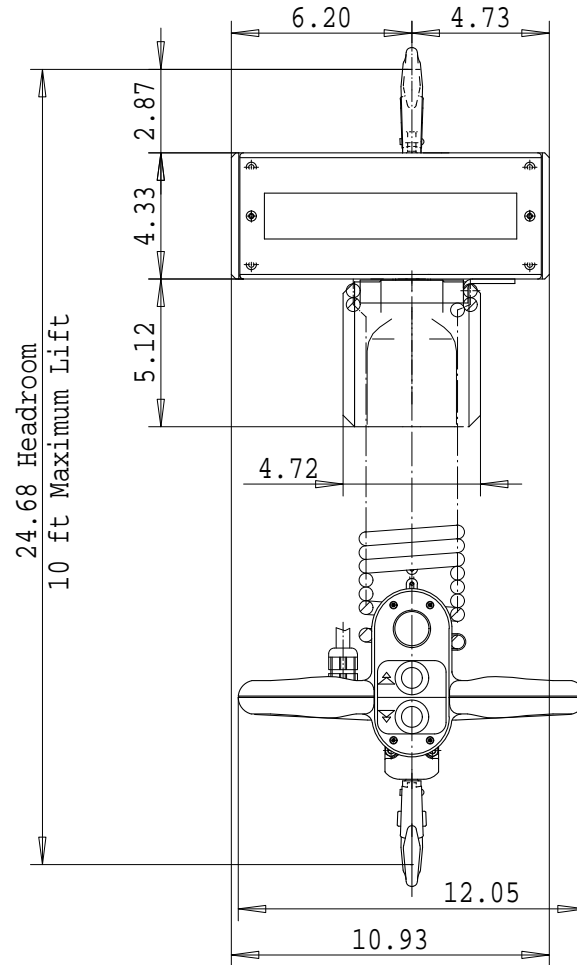
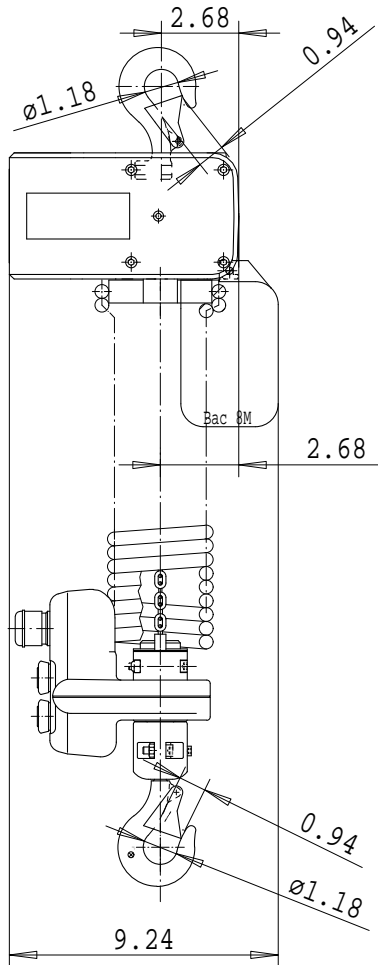

Note: Digichain option - available only for single fall

LOAD MATE CHAIN HOIST MODEL NUMBER							FLG CODE	TROLLEY DIMENSIONS						Chd	Appd	p_2213417109 File
FR	CAP TON	LFT FT	SUSP	1 SPEED FPM	2 SPEED FPM(4:1)	FALL		FLG CODE	FLANGE RANGES	MAX. TD	MAX TW	MIN. WS	MAX FLG THK	2003-03-31 Date	2213417109	
LM1	1/8	10	TH	16S	---	1	---	---	---	---	---	---	R&M	R&M Materials Handling Inc.		
													MATERIALS	4501 Gateway Blvd, Springfield		
													HANDLING	LM1 DIGICHAIN		
													INC.	Issue	02/2007	