

Dimensions are for reference in estimating only. Use of various modifications may affect overall dimensional outline. Where dimensions are critical, request certified drawings for construction. All dimensions are in millimeters unless otherwise noted.

2213417093

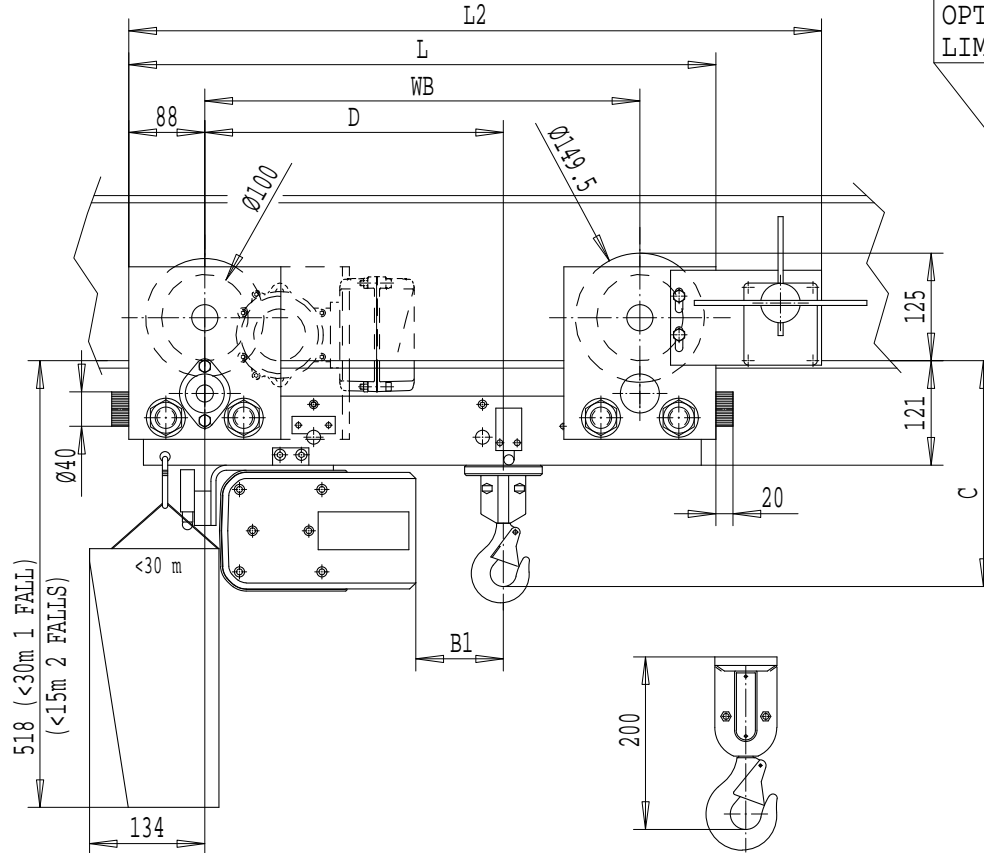

OPTIONAL TRAVEL
LIMIT SWITCH

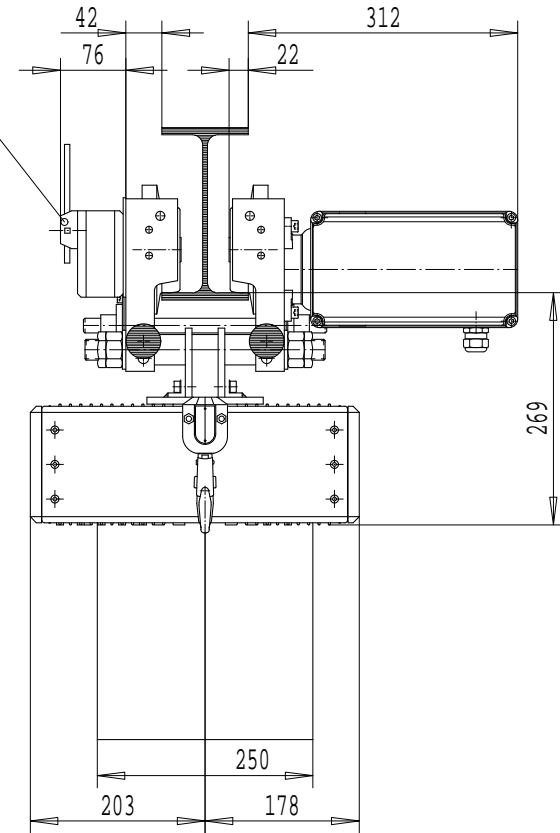

LENGTH- FALLS	C	B1	D	WB	L	L2
SHORT- 1 FALL	254	59	346	504	680	803
- 2 FALLS	304	80	367	504	680	803
LONG - 1 FALL	254	457	745	903	1080	1202
- 2 FALLS	304	478	766	903	1080	1202

LOAD MATE CHAIN HOIST MODEL NUMBER								FLG CODE
FR	CAP Kg	LIFT m	SUSP	1 SPEED m/MIN	2 SPEED m/MIN(4:1)	FALL		
LM05	250	3	ML*	4.9S, 9.8S	9.8T	1	---	
LM05	500	3	ML*	4.9S, 9.8S	9.8T	1	---	
LM05	1000	3	ML*	---	4.9T	2	---	

TROLLEY DIMENSIONS					
FLG CODE	FLANGE RANGES	MAX. TD	MAX TW	MIN. WS	MAX FLG THK
---	58 - 310	---	---	14	25

Chd	Appd	p_2213417093 File
2003-05-05 Date	2213417093	
R&M	R&M Materials Handling Inc.	
MATERIALS HANDLING	4501 Gateway Blvd, Springfield	
INC.	LM05 MLS / MLL	Issue 02/2007