

Dimensions are for reference in estimating only. Use of various modifications may affect overall dimensional outline. Where dimensions are critical, request certified drawings for construction. All dimensions are in millimeters unless otherwise noted.

2213417088

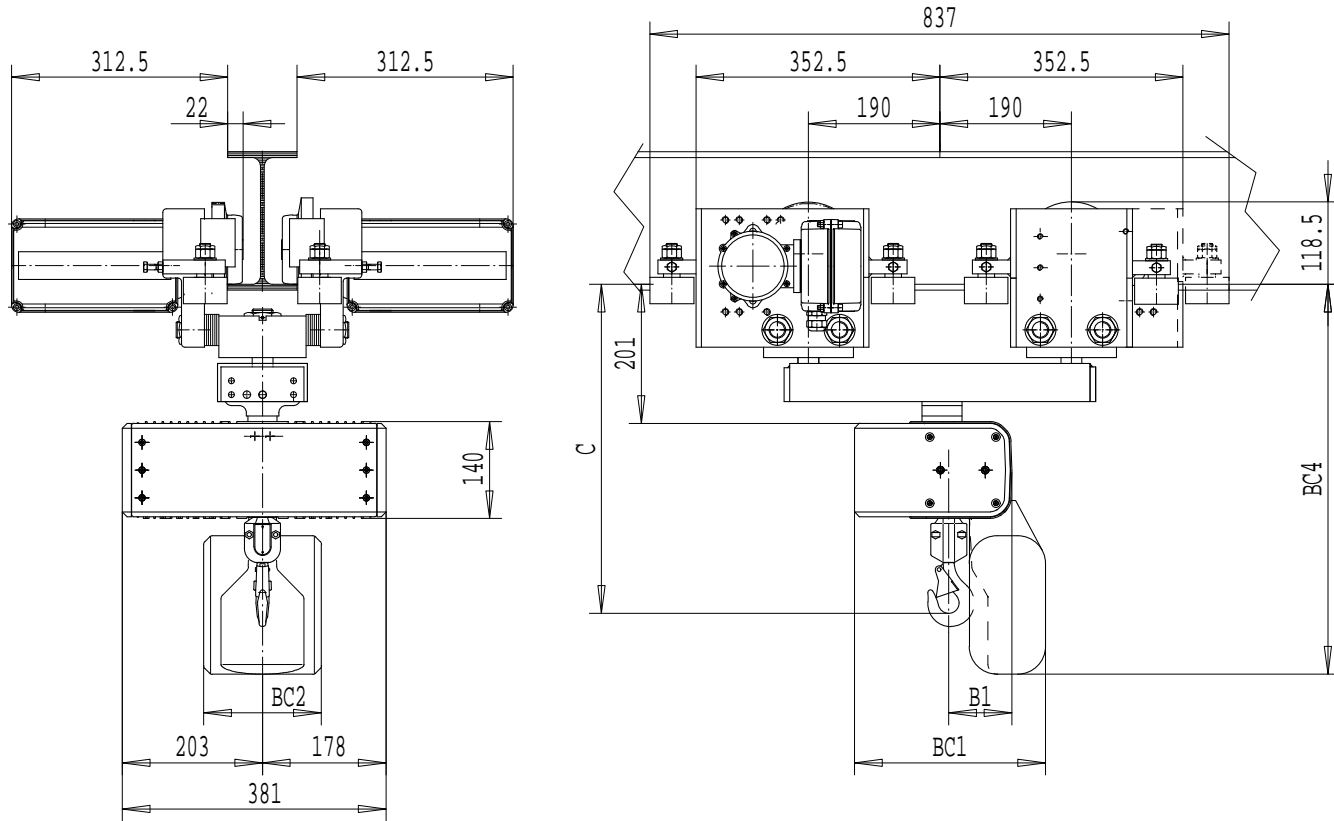

	C	B1	BC1				BC2				BC4			
LIFT	---	---	<8m	<16m	<30m	<46m	<8m	<16m	<30m	<46m	<8m	<16m	<30m	<46m
1 FALL	478	91	276	316	311	311	170	160	150	320	564	624	689	689
LIFT	---	---	<4m	<8m	<15m	<23m	<4m	<8m	<15m	<23m	<4m	<8m	<15m	<23m
2 FALLS	528	112	276	316	311	311	170	160	150	320	564	624	689	689

MINIMUM RADIUS CURVE: 0.800 m

LOAD MATE CHAIN HOIST MODEL NUMBER								TROLLEY DIMENSIONS						Chd	Appd	p_2213417088 File
FR	CAP Kg	LFT m	SUSP	1 SPEED m/MIN	2 SPEED m/MIN(4:1)	FALL	FLG CODE	FLG CODE	FLANGE RANGES	MAX. TD	MAX TW	MIN. WS	MAX FLG THK	2003-04-23 Date	2213417088	
LM05	250	3	SW	4.9S,9.8S	9.8T	1	---	---	66 - 292	---	---	38	22		R&M Materials Handling Inc.	
LM05	500	3	SW	4.9S,9.8S	9.8T	1	---								4501 Gateway Blvd, Springfield	
LM05	1000	3	SW	---	4.9T	2	---								LM05 SWIVEL TROLLEY	
															Issue	02/2007

R&M MATERIALS HANDLING INC.	LM05 SWIVEL TROLLEY	Issue 02/2007
--------------------------------------	---------------------	------------------