

Dimensions are for reference in estimating only. Use of various modifications may affect overall dimensional outline. Where dimensions are critical, request certified drawings for construction. All dimensions are in millimeters unless otherwise noted.

2213417075

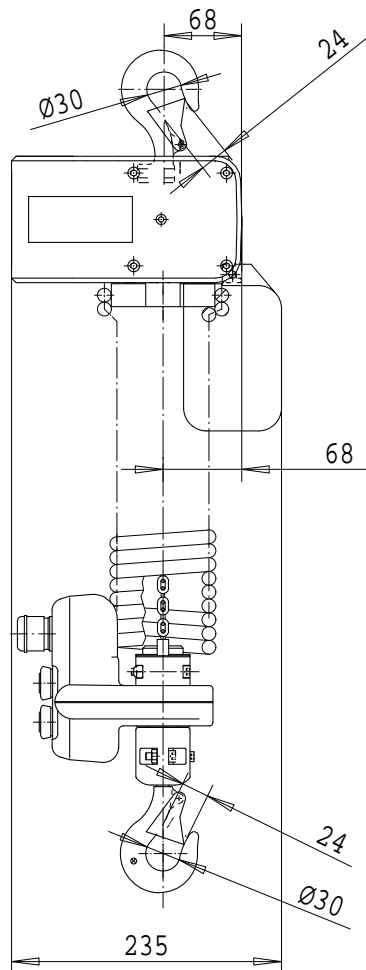

627 Headroom
3m Maximum Lift

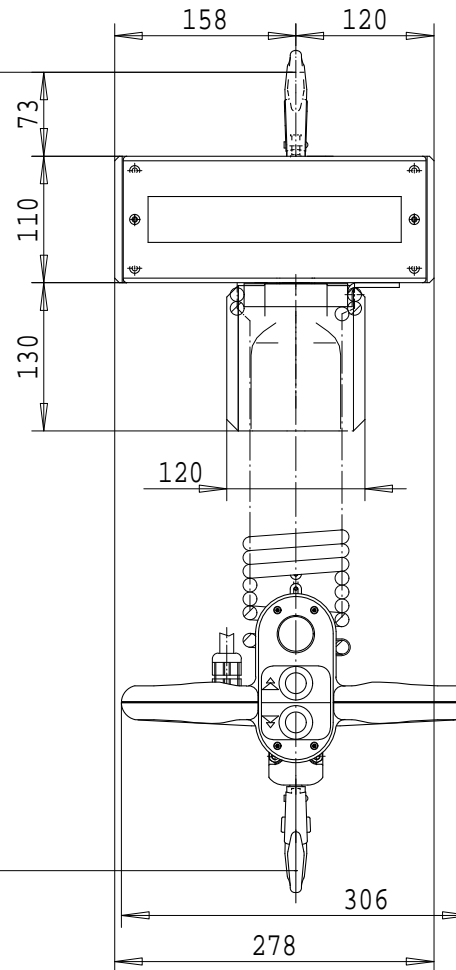

Note: Digichain option only available for single fall hoists.

| LOAD MATE CHAIN HOIST MODEL NUMBER | | | | | | | TROLLEY DIMENSIONS | | | | | | | Chd | Appd | p_2213417075 File |
|------------------------------------|-----------|----------|------|------------------|-----------------------|------|--------------------|-------------|------------------|------------|-----------|------------|----------------|--------------------|--------------------------------|----------------------|
| FR | CAP Kg | LFT m | SUSP | 1 SPEED m/MIN | 2 SPEED m/MIN(4:1) | FALL | FLG CODE | FLG CODE | FLANGE RANGES | MAX. TD | MAX TW | MIN. WS | MAX FLG THK | 2003-03-31 Date | 2213417075 | |
| LM1 | 125 | 3 | TH | --- | 9.8T | 1 | --- | --- | --- | --- | --- | --- | --- | R&M | R&M Materials Handling Inc. | |
| | | | | | | | | | | | | | | MATERIALS | 4501 Gateway Blvd, Springfield | |
| | | | | | | | | | | | | | | HANDLING | LM1 DIGICHAIN | |
| | | | | | | | | | | | | | | INC. | Issue | 02/2007 |