

Dimensions are for reference in estimating only. Use of various modifications may affect overall dimensional outline. Where dimensions are critical, request certified drawings for construction. All dimensions are in millimeters unless otherwise noted.

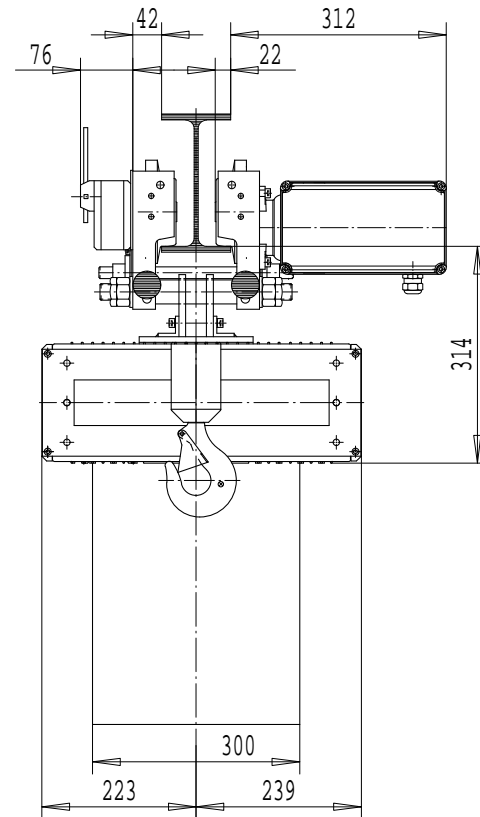
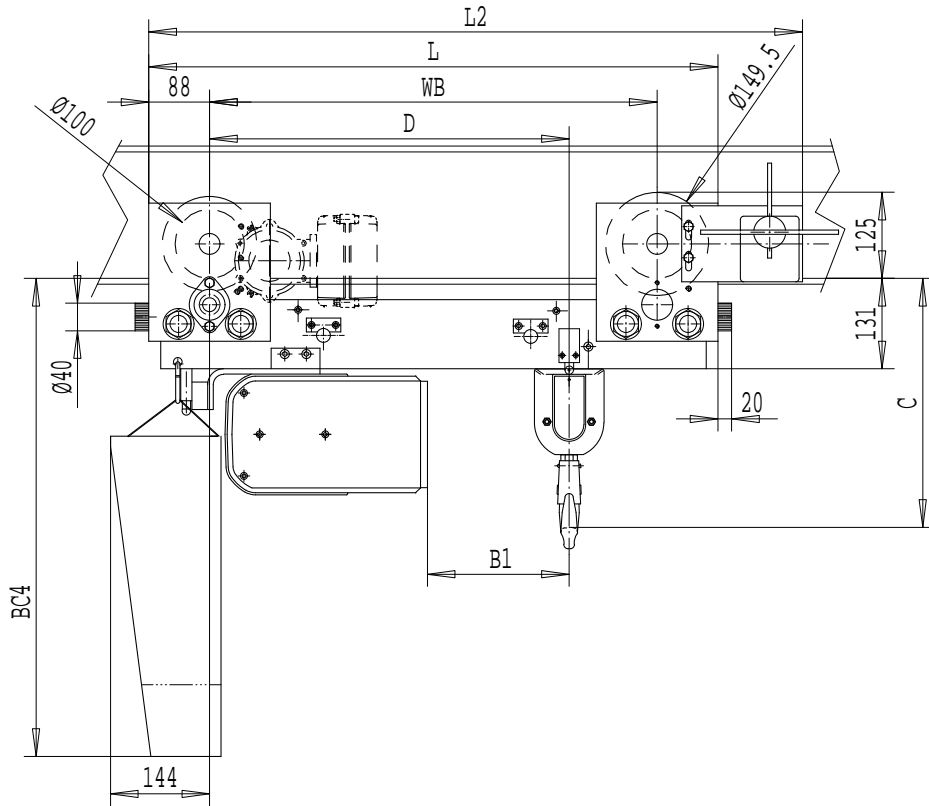

LENGTH- FALLS	C	B1	D	WB	L	L2	BC4 <LIFT: DIM.
SHORT- 1 FALL	313	135	491	648	824	947	<30m: 589 <40m: 694
- 2 FALLS	361	165	521	648	824	947	<15m: 589 <20m: 694
LONG - 1 FALL	313	450	806	963	1139	1262	<30m: 589 <40m: 694
- 2 FALLS	361	480	836	963	1139	1262	<15m: 589 <20m: 694

LOAD MATE CHAIN HOIST MODEL NUMBER							TROLLEY DIMENSIONS						
FR	CAP Kg	LIFT m	SUSP	1 SPEED m/MIN	2 SPEED m/MIN(4:1)	FALL	FLG CODE	FLG CODE	FLANGE RANGES	MAX. TD	MAX. TW	MIN. WS	MAX. FLG THK
LM10	500	3	ML*	---	19.5T	1	---	---	58 - 310	---	---	14	25
LM10	1000	3	ML*	4.9S, 9.8S	9.8T	1	---						

Chd	Appd	p_2213417094 File
2003-05-06 Date	2213417094	
R&M	R&M Materials Handling Inc.	
MATERIALS HANDLING	4501 Gateway Blvd, Springfield	
INC.	LM10 MLS / MLL	Issue 02/2007