

2213417096

Dimensions are for reference in estimating only. Use of various modifications may affect overall dimensional outline. Where dimensions are critical, request certified drawings for construction. All dimensions are in millimeters unless otherwise noted.

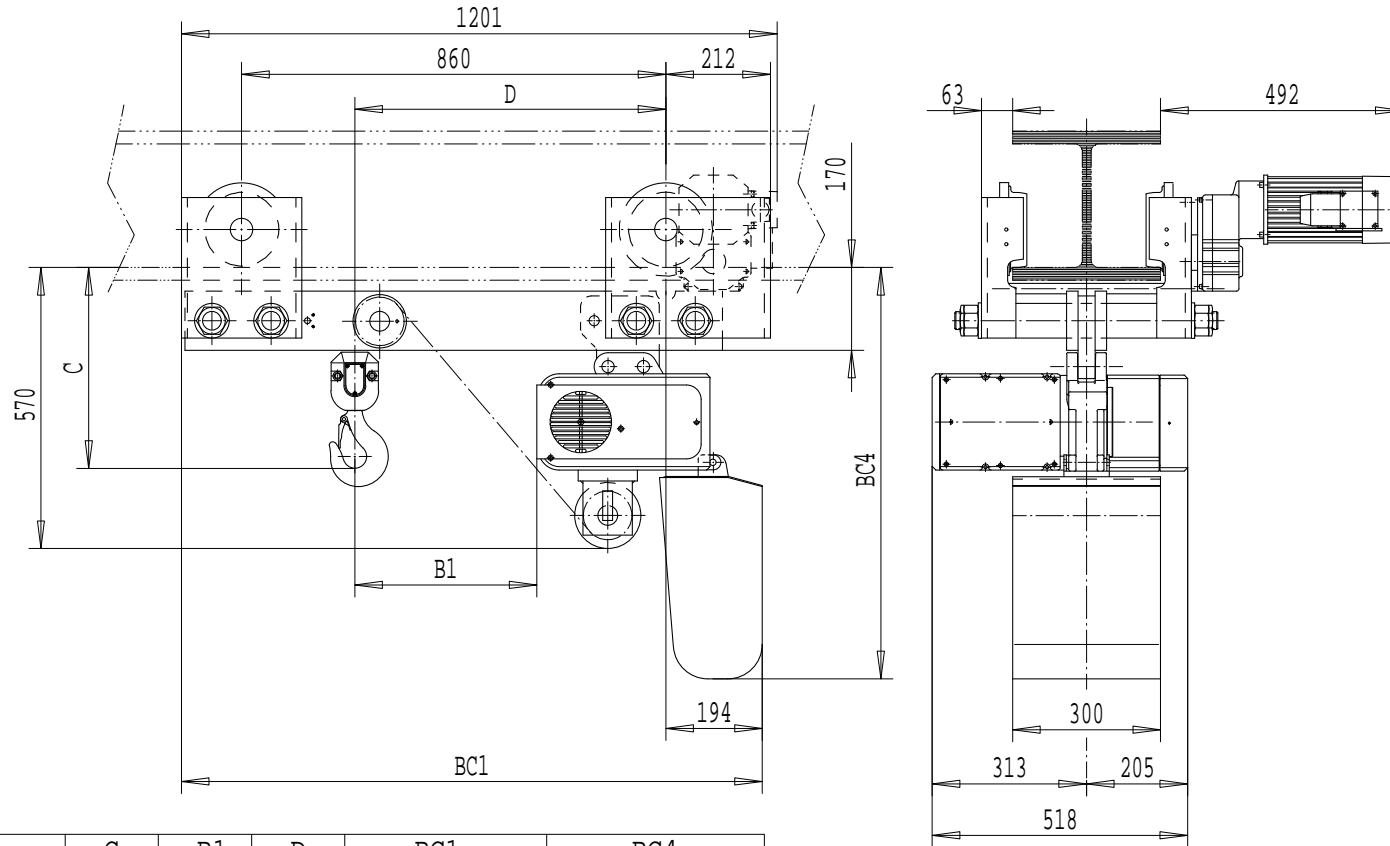

	C	B1	D	BC1		BC4	
LIFT	---	---	---	<16m	<46m	<16m	<46m
1 FALL	381	452	631	1178	1348	839	998
LIFT	---	---	---	<8m	<23m	<8m	<23m
2 FALLS	481	501	680	1178	1348	839	998

LOAD MATE CHAIN HOIST MODEL NUMBER							FLG CODE
FR	CAP Kg	LIFT m	SUSP	1 SPEED m/MIN	2 SPEED m/MIN(4:1)	FALL	
LM16	1000	3	ML	-----	19.5T	1	---
LM16	1500	3	ML	-----	9.8T	1	---
LM16	3000	3	ML	-----	4.9T	2	---

TROLLEY DIMENSIONS					
FLG CODE	FLANGE RANGES	MAX. TD	MAX. TW	MIN. WS	MAX. FLG THK
---	58 - 310	---	305	38	22

Chd	Appd	p_2213417096 File
2003-05-21 Date	2213417096	
R&M	R&M Materials Handling Inc.	
MATERIALS HANDLING	4501 Gateway Blvd, Springfield	
INC.	LM16 ML	Issue 02/2007