

Dimensions are for reference in estimating only. Use of various modifications may affect overall dimensional outline. Where dimensions are critical, request certified drawings for construction. All dimensions are in millimeters unless otherwise noted.

2213417090

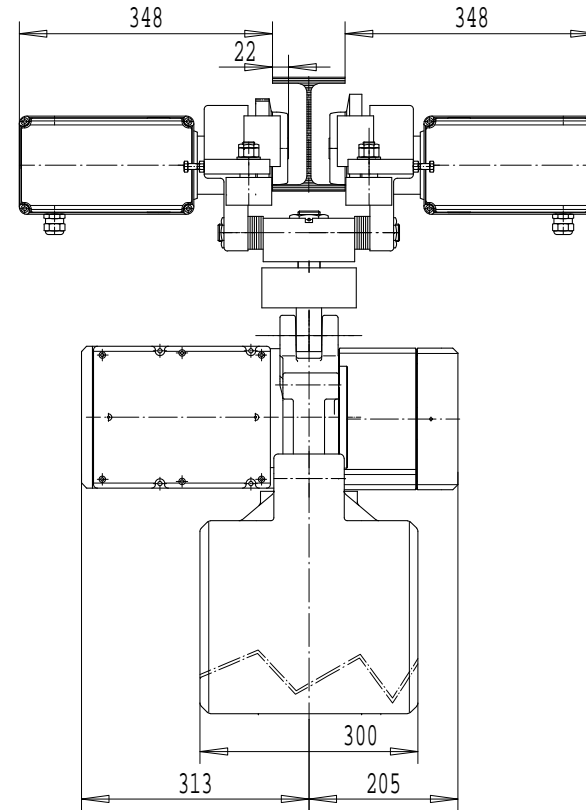
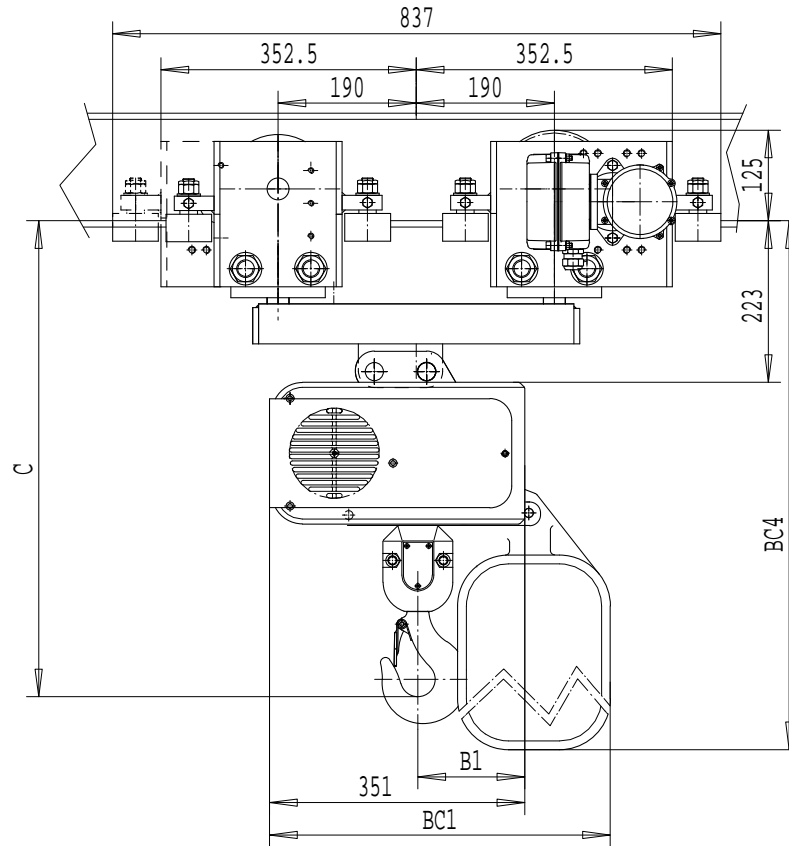

	C	B1	BC1			BC4		
LIFT	---	---	<16m	<30m	<46m	<16m	<30m	<46m
1 FALL	619	147	469	639	709	780	941	1141
LIFT	---	---	<8m	<15m	<23m	<8m	<15m	<23m
2 FALLS	719	196	469	639	709	780	941	1141

LOAD MATE CHAIN HOIST MODEL NUMBER								TROLLEY DIMENSIONS						Chd	Appd	p_2213417090 File
FR	CAP Kg	LFT m	SUSP	1 SPEED m/MIN	2 SPEED m/MIN(4:1)	FALL	FLG CODE	FLG CODE	FLANGE RANGES	MAX. TD	MAX TW	MIN. WS	MAX FLG THK	2003-04-29 Date	2213417090	
LM16	1000	3	SW	---	19.5T	1	---	---	66 - 292	---	---	22	30		R&M Materials Handling Inc.	
LM16	1500	3	SW	---	9.8T	1	---								4501 Gateway Blvd, Springfield	
LM16	3000	3	SW	---	4.9T	2	---								LM16 SWIVEL TROLLEY	
															Issue	02/2007

Chd	Appd	p_2213417090 File
2003-04-29 Date	2213417090	
R&M	R&M Materials Handling Inc.	
MATERIALS HANDLING	4501 Gateway Blvd, Springfield	
INC.	LM16 SWIVEL TROLLEY	Issue 02/2007