

Dimensions are for reference in estimating only. Use of various modifications may affect overall dimensional outline. Where dimensions are critical, request certified drawings for construction. All dimensions are in millimeters unless otherwise noted.

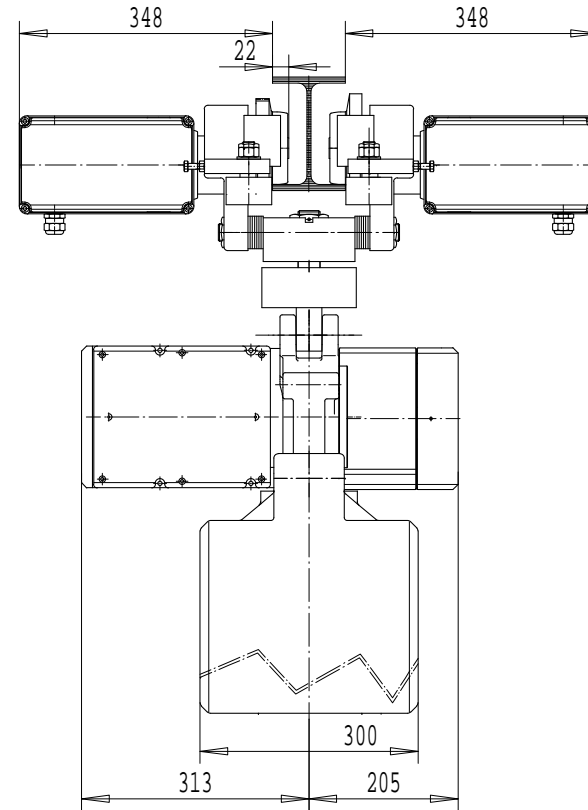
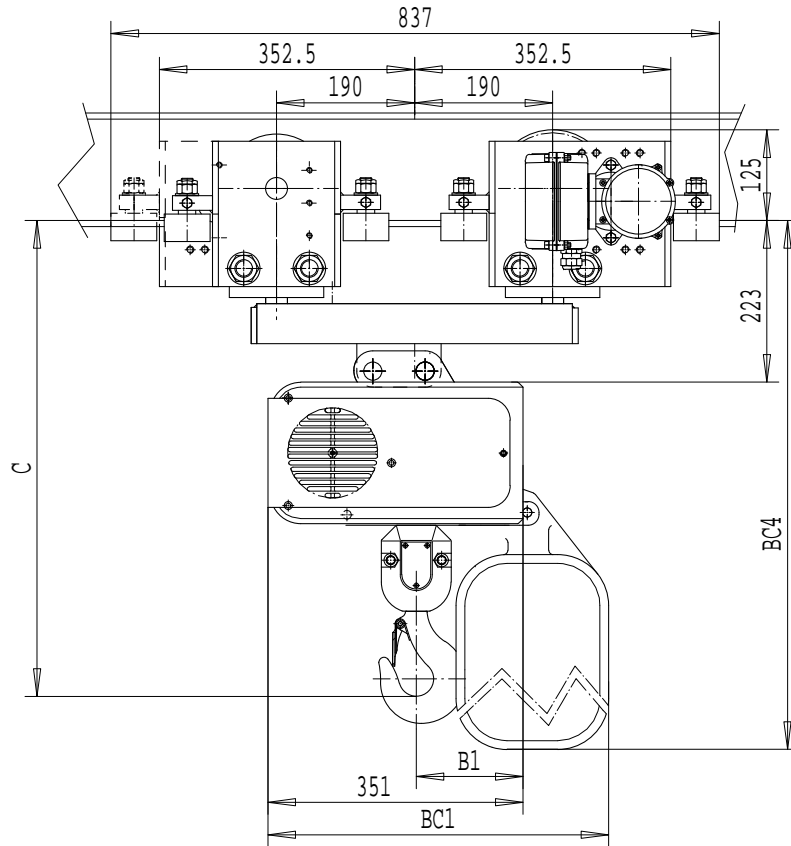

	C	B1	BC1			BC4		
LIFT	---	---	<12m	<30m	<46m	<12m	<30m	<46m
1 FALL	650	147	469	639	709	780	941	1141
LIFT	---	---	<6m	<15m	<23m	<6m	<15m	<23m
2 FALLS	761	196	469	639	709	780	941	1141

LOAD MATE CHAIN HOIST MODEL NUMBER							FLG CODE
FR	CAP Kg	LFT m	SUSP	1 SPEED m/MIN	2 SPEED m/MIN(4:1)	FALL	
LM20	2000	3	SW	---	9.8T	1	---
LM20	4000	3	SW	---	4.9T	2	---

TROLLEY DIMENSIONS					
FLG CODE	FLANGE RANGES	MAX. TD	MAX. TW	MIN. WS	MAX. FLG THK
---	90 - 292	---	---	46	30

Chd	Appd	p_2213417091 File
2003-04-29 Date	2213417091	
R&M	R&M Materials Handling Inc.	
MATERIALS HANDLING	4501 Gateway Blvd, Springfield	
INC.	LM20 SWIVEL TROLLEY	Issue 02/2007

2213417091