

Dimensions are for reference in estimating only. Use of various modifications may affect overall dimensional outline. Where dimensions are critical, request certified drawings for construction. All dimensions are in millimeters unless otherwise noted.

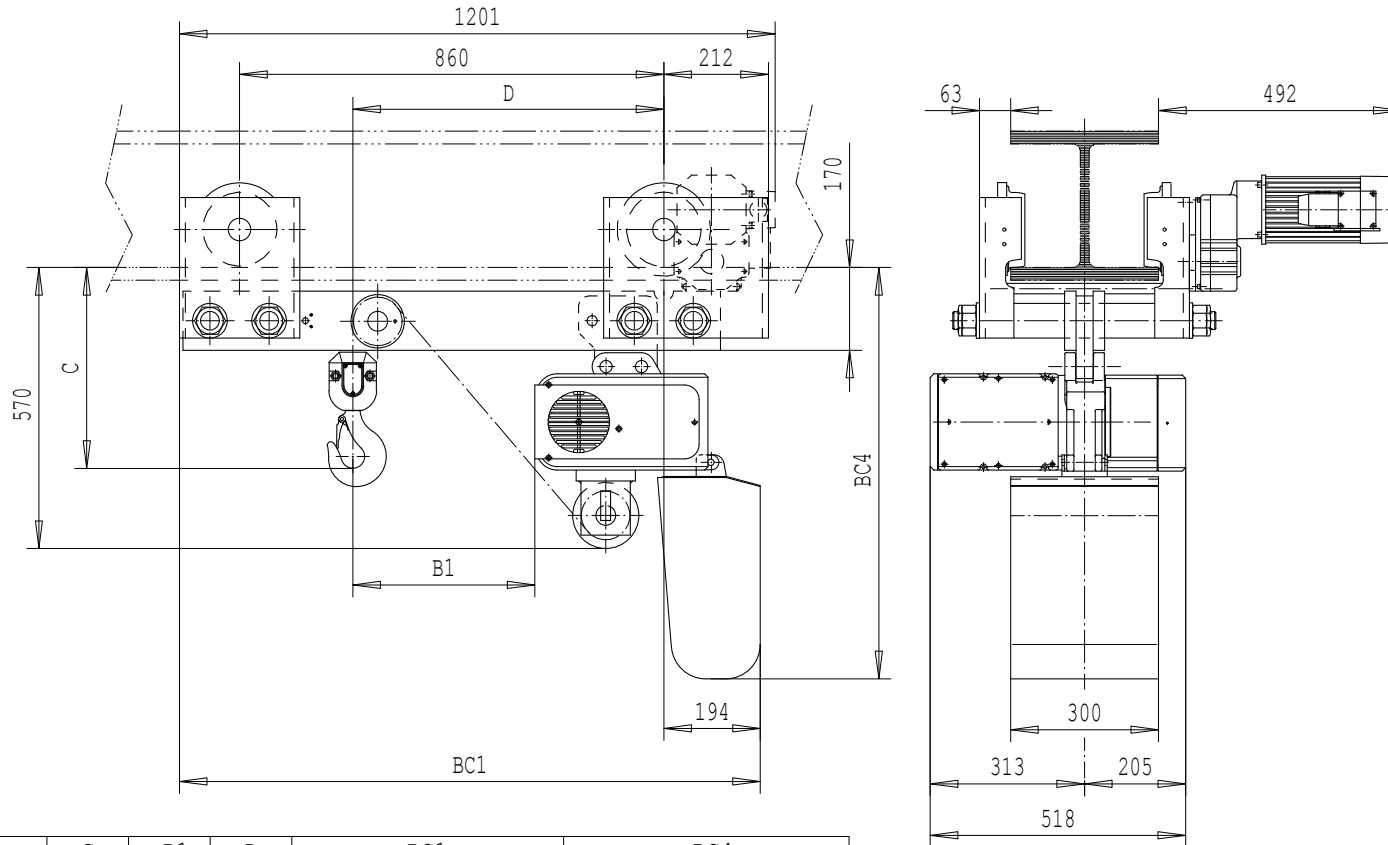

	C	B1	D	Bc1			Bc4		
LIFT	---	---	---	<12m	<30m	<46m	<12m	<30m	<46m
1 FALL	411	452	631	1178	1348	1418	839	998	1198
LIFT	---	---	---	<6m	<15m	<23m	<6m	<15m	<23m
2 FALLS	521	501	680	1178	1348	1418	839	998	1198

LOAD MATE CHAIN HOIST MODEL NUMBER							FLG CODE
FR	CAP Kg	LIFT m	SUSP	1 SPEED m/MIN	2 SPEED m/MIN(4:1)	FALL	
LM25	2500	3	ML	---	7.4T	1	---
LM25	5000	3	ML	---	3.7T	2	---

TROLLEY DIMENSIONS					
FLG CODE	FLANGE RANGES	MAX. TD	MAX. TW	MIN. WS	MAX. FLG THK
---	100 - 310	---	305	38	22

Chd	Appd	p_2213417098 File
2003-05-21 Date	2213417098	
R&M MATERIALS HANDLING INC.	R&M Materials Handling Inc. 4501 Gateway Blvd, Springfield LM25 ML	
	Issue	02/2007

2213417098