

2213417093

Dimensions are for reference in estimating only. Use of various modifications may affect overall dimensional outline. Where dimensions are critical, request certified drawings for construction. All dimensions are in inches unless otherwise noted.

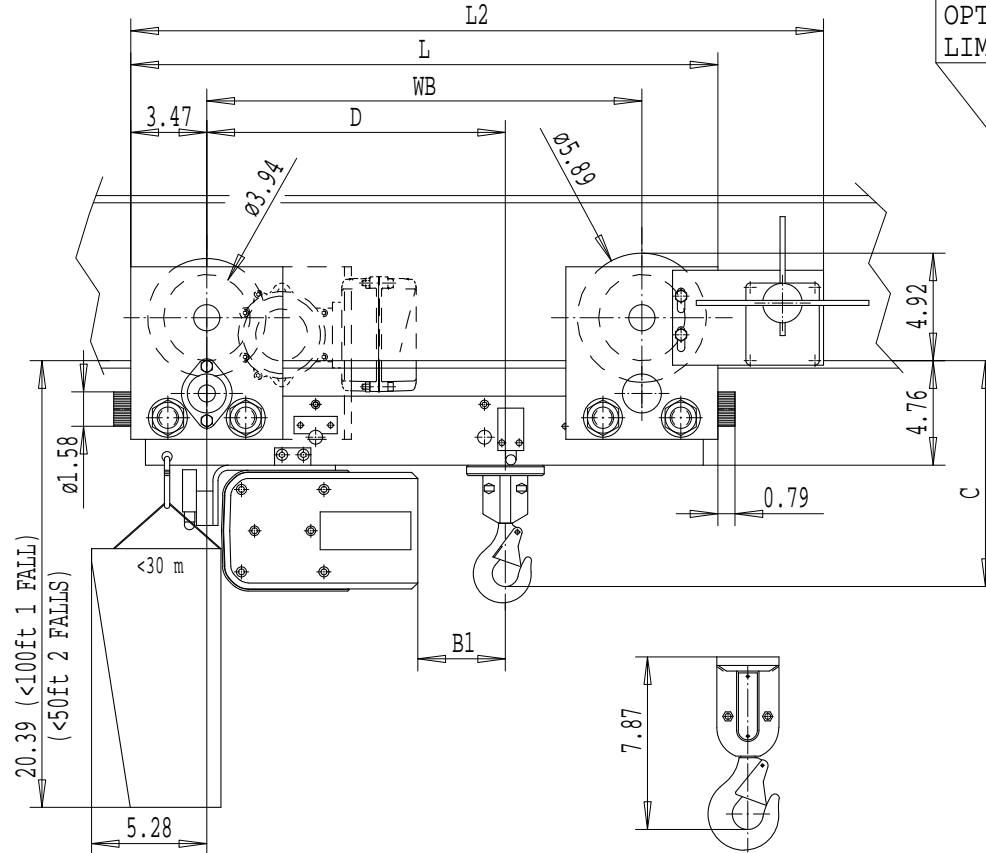

OPTIONAL TRAVEL
LIMIT SWITCH

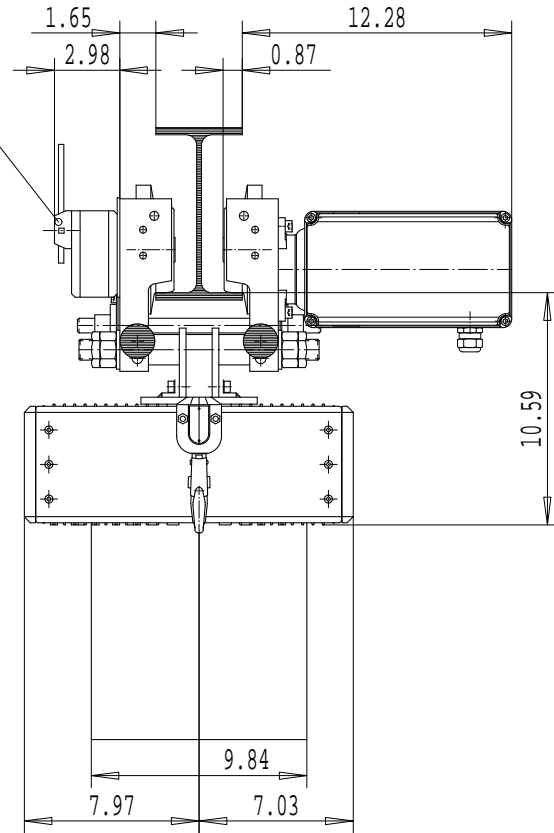

LENGTH-	FALLS	C	B1	D	WB	L	L2
SHORT-	1 FALL	10.00	2.32	13.62	19.84	26.77	31.61
	- 2 FALLS	11.97	3.15	14.45	19.84	26.77	31.61
LONG	- 1 FALL	10.00	17.99	29.33	35.55	42.52	47.32
	- 2 FALLS	11.97	18.82	30.16	35.55	42.52	47.32

LOAD MATE CHAIN HOIST MODEL NUMBER							FLG CODE
FR	CAP TON	LIFT FT	SUSP	1 SPEED FPM	2 SPEED FPM(4:1)	FALL	
LM05	1/4	10	ML*	16S, 32S	32T	1	---
LM05	1/2	10	ML*	16S, 32S	32T	1	---
LM05	1	10	ML*	---	16T	2	---

TROLLEY DIMENSIONS					
FLG CODE	FLANGE RANGES	MAX. TD	MAX TW	MIN. WS	MAX FLG THK
---	2.28 - 12.20	---	---	0.55	.98

Chd	Appd	p_2213417093 File
2003-05-05 Date	2213417093	
R&M	R&M Materials Handling Inc.	
MATERIALS HANDLING	4501 Gateway Blvd, Springfield	
INC.	LM05 MLS / MLL	Issue 02/2007