

Dimensions are for reference in estimating only. Use of various modifications may affect overall dimensional outline. Where dimensions are critical, request certified drawings for construction. All dimensions are in inches unless otherwise noted.

2213417083

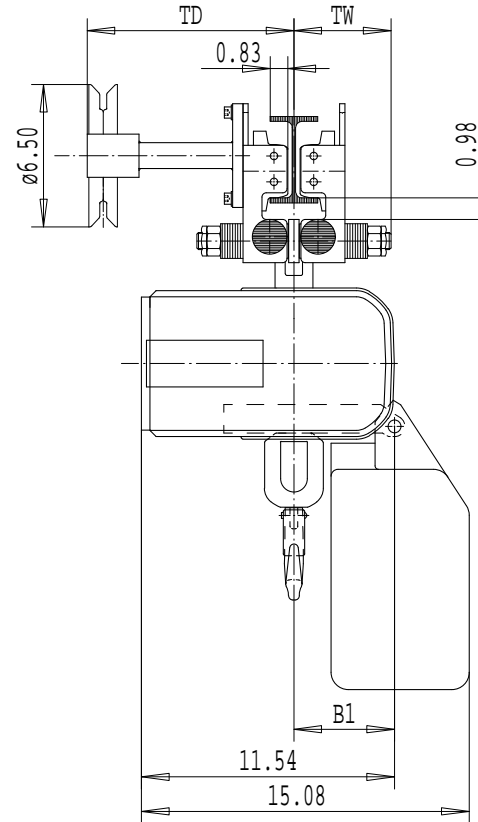
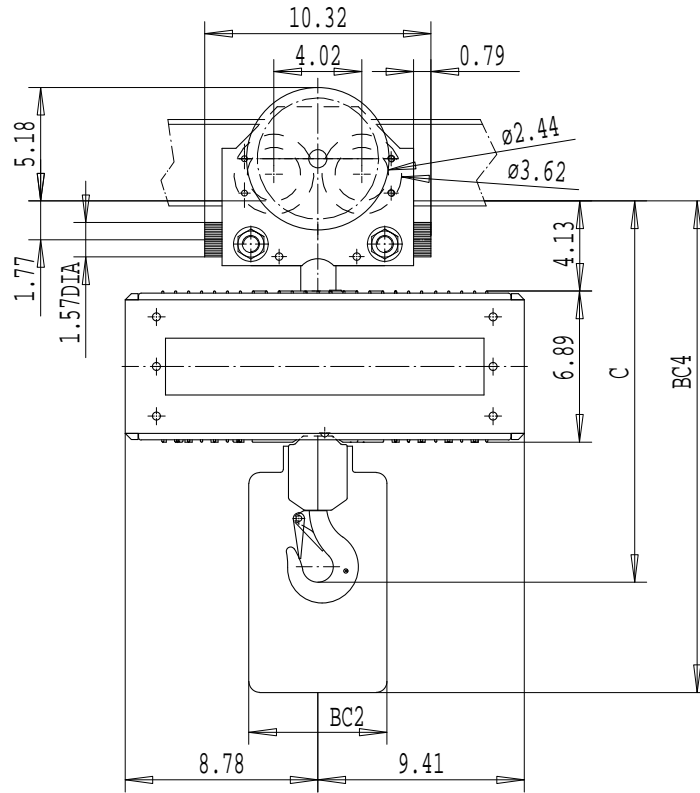

	C	B1	BC2				BC4			
LIFT	---	---	<25ft	<50ft	<100ft	<150ft	<25ft	<50ft	<100ft	<150ft
1 FALL	18.23	4.57	6.30	5.91	12.60	12.60	23.23	25.79	25.79	30.51
LIFT	---	---	<12ft	<25ft	<50ft	<75ft	<12ft	<25ft	<50ft	<75ft
2 FALLS	20.63	5.71	6.30	5.91	12.60	12.60	23.23	25.79	25.79	30.51

LOAD MATE CHAIN HOIST MODEL NUMBER							FLG CODE
FR	CAP TON	LFT FT	SUSP	1 SPEED FPM	2 SPEED FPM(4:1)	FALL	
LM10	1/2	10	HGX	---	64T	1	1 - 5
LM10	1	10	HGX	16S, 32S	32T	1	1 - 5

TROLLEY DIMENSIONS					
FLG CODE	FLANGE RANGES	MAX. TD	MAX. TW	MIN. WS	MAX FLG THK
1	2.28 - 3.94	10.32	4.43	---	.79
2	4.17 - 5.90	11.30	5.31	---	.79
3	6.10 - 7.87	12.29	6.30	---	.79
4	8.11 - 9.76	13.23	7.28	---	.79
5	10.23-12.09	14.40	8.46	---	.79

Chd	Appd	p_2213417083 File
2003-04-09 Date	2213417083	
R&M MATERIALS HANDLING INC.	R&M Materials Handling Inc. 4501 Gateway Blvd, Springfield	Issue 02/2007