

Dimensions are for reference in estimating only. Use of various modifications may affect overall dimensional outline. Where dimensions are critical, request certified drawings for construction. All dimensions are in inches unless otherwise noted.

2213417090

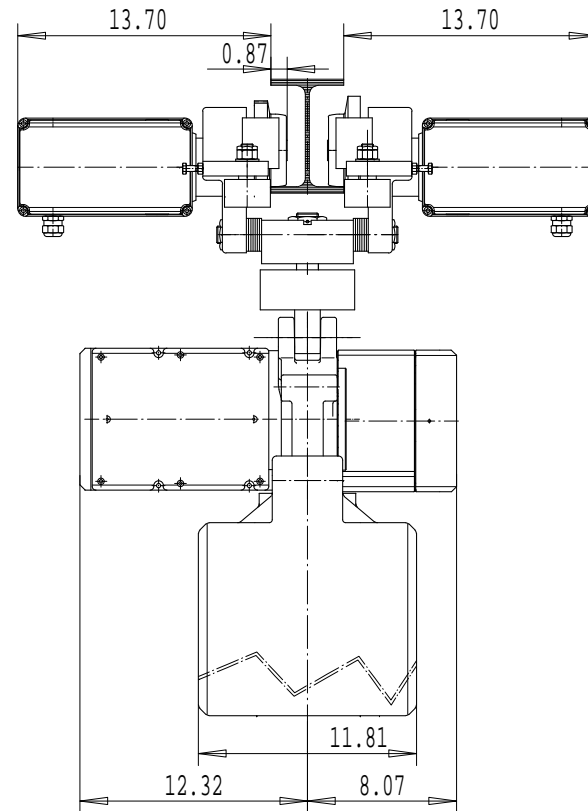
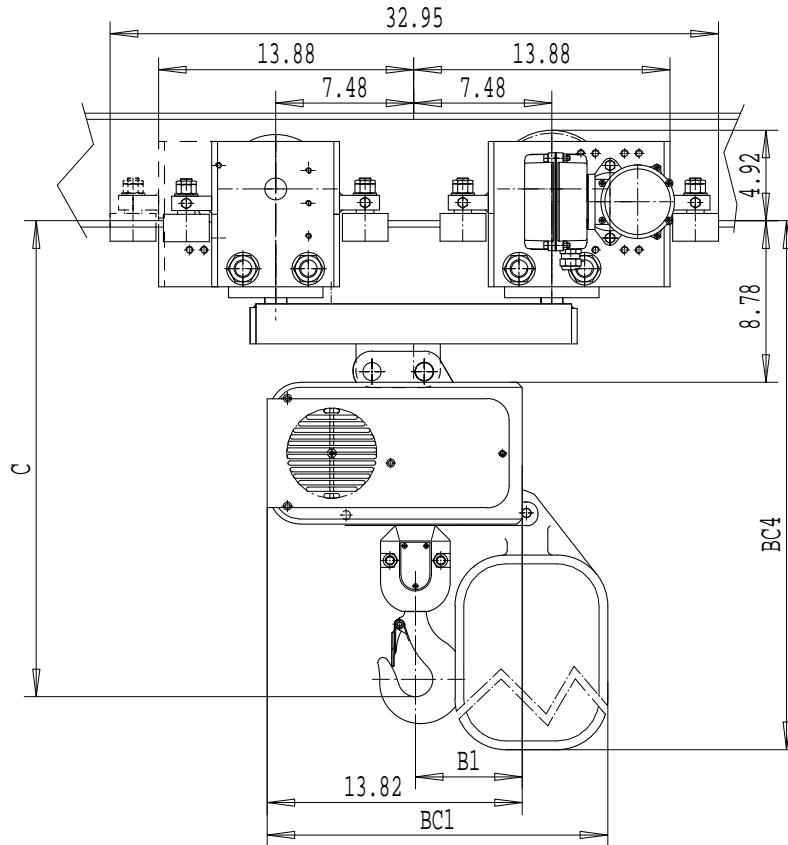

	C	B1	BC1			BC4		
LIFT	---	---	<50ft	<100ft	<150ft	<50ft	<100ft	<150ft
1 FALL	24.37	5.79	18.47	25.16	27.91	30.71	37.05	44.92
LIFT	---	---	<25ft	<15ft	<75ft	<25ft	<50ft	<75ft
2 FALLS	28.31	7.72	18.47	25.16	27.91	30.71	37.05	44.92

LOAD MATE CHAIN HOIST MODEL NUMBER							TROLLEY DIMENSIONS						
FR	CAP TON	LFT FT	SUSP	1 SPEED FPM	2 SPEED FPM(4:1)	FALL	FLG CODE	FLG CODE	FLANGE RANGES	MAX. TD	MAX TW	MIN. WS	MAX FLG THK
LM16	1	10	SW	---	64T	1	---	---	2.60-11.50	---	---	.87	1.18
LM16	1 1/2	10	SW	---	32T	1	---						
LM16	3	10	SW	---	16T	2	---						

Chd	Appd	p_2213417090 File
2003-04-29 Date	2213417090	
R&M	R&M Materials Handling Inc.	
MATERIALS HANDLING	4501 Gateway Blvd, Springfield	
INC.	LM16 SWIVEL TROLLEY	Issue 02/2007