

Dimensions are for reference in estimating only. Use of various modifications may affect overall dimensional outline. Where dimensions are critical, request certified drawings for construction. All dimensions are in millimeters unless otherwise noted.

2213417086

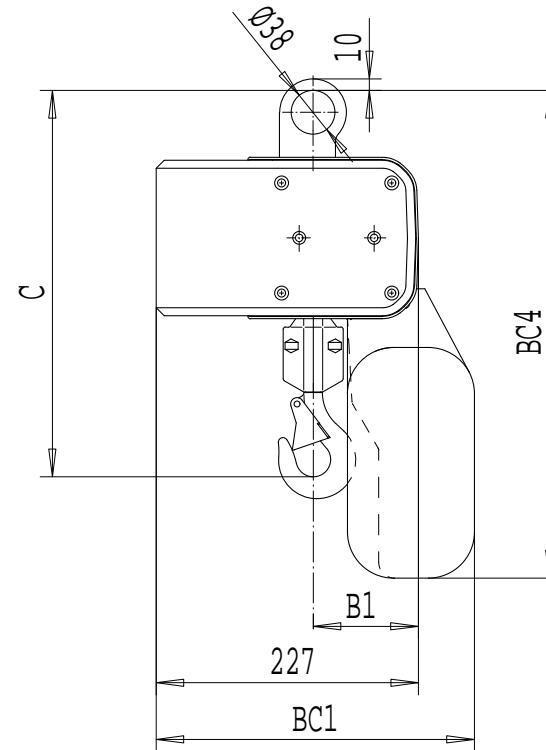
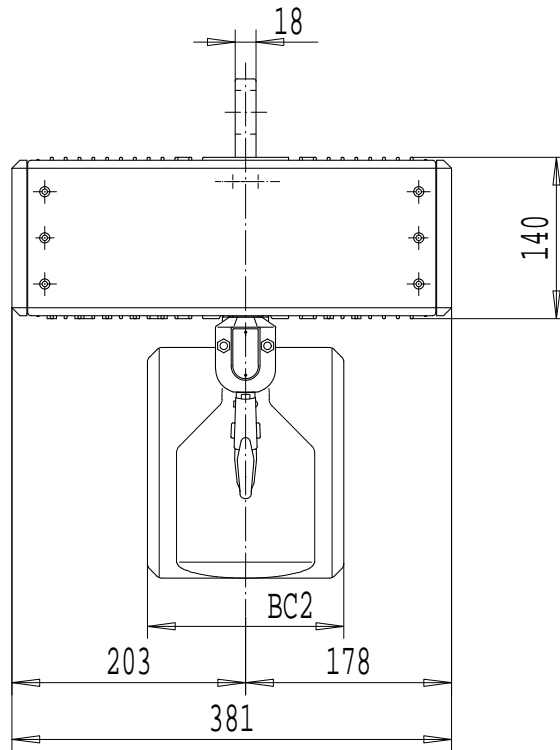

| | C | B1 | BC1 | | | | BC2 | | | | BC4 | | | |
|---------|-----|-----|-----|------|------|------|-----|------|------|------|-----|------|------|------|
| LIFT | --- | --- | <8m | <16m | <30m | <50m | <8m | <16m | <30m | <50m | <8m | <16m | <30m | <50m |
| 1 FALL | 335 | 91 | 276 | 316 | 311 | 311 | 160 | 150 | 320 | 320 | 426 | 486 | 551 | 551 |
| LIFT | --- | --- | <4m | <8m | <15m | <25m | <4m | <8m | <15m | <25m | <4m | <8m | <15m | <25m |
| 2 FALLS | 385 | 112 | 276 | 316 | 311 | 311 | 160 | 150 | 320 | 320 | 426 | 486 | 551 | 551 |

| LOAD MATE CHAIN HOIST MODEL NUMBER | | | | | | | | FLG CODE |
|------------------------------------|--------|-------|------|---------------|--------------------|------|-----|----------|
| FR | CAP Kg | LFT m | SUSP | 1 SPEED m/MIN | 2 SPEED m/MIN(4:1) | FALL | | |
| LM05 | 250 | 3 | LP | 4.9S,9.8S | 9.8T | 1 | --- | |
| LM05 | 500 | 3 | LP | 4.9S,9.8S | 9.8T | 1 | --- | |
| LM05 | 500 | 3 | LP | --- | 4.9T | 2 | --- | |
| LM05 | 1000 | 3 | LP | --- | 4.9T | 2 | --- | |

| TROLLEY DIMENSIONS | | | | | |
|--------------------|---------------|---------|--------|---------|-------------|
| FLG CODE | FLANGE RANGES | MAX. TD | MAX TW | MIN. WS | MAX FLG THK |
| --- | --- | --- | --- | --- | --- |
| | | | | | |
| | | | | | |
| | | | | | |

| | | |
|-----------------------|--------------------------------|----------------------|
| Chd | Appd | p_2213417086 File |
| 2003-04-22 Date | 2213417086 | |
| R&M | R&M Materials Handling Inc. | |
| MATERIALS HANDLING | 4501 Gateway Blvd, Springfield | |
| INC. | LM05 LP | Issue 02/2007 |