

Dimensions are for reference in estimating only. Use of various modifications may affect overall dimensional outline. Where dimensions are critical, request certified drawings for construction. All dimensions are in millimeters unless otherwise noted.

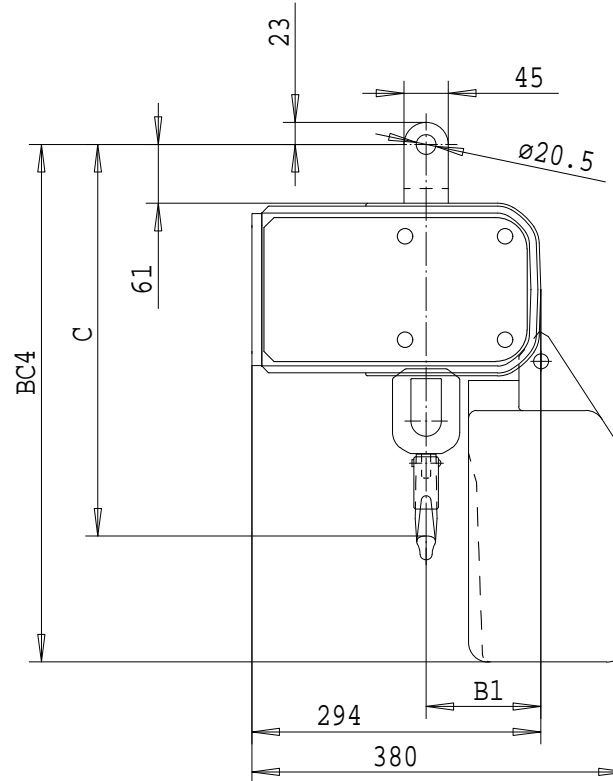
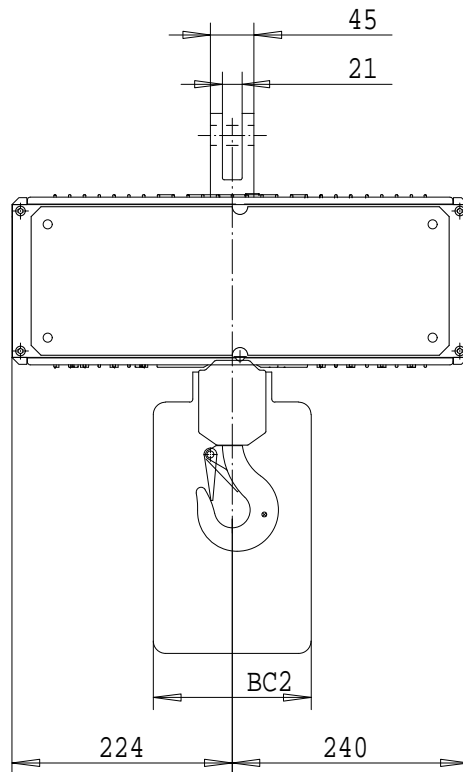

2213417030

	C	B1	BC2				BC4			
LIFT	---	---	<8m	<16m	<30m	<46m	<8m	<16m	<30m	<46m
1 FALL	399	116	160	150	320	320	546	611	611	731
LIFT	---	---	<4m	<8m	<15m	<23m	<4m	<8m	<15m	<23m
2 FALLS	460	145	160	150	320	320	546	611	611	731

LOAD MATE CHAIN HOIST MODEL NUMBER								TROLLEY DIMENSIONS						KHSJST	Chd	Appd	p_2213417030 File
FR	CAP Kg	LFT m	SUSP	1 SPEED m/MIN	2 SPEED m/MIN(4:1)	FALL	FLG CODE	FLG CODE	FLANGE RANGES	MAX. TD	MAX TW	MIN. WS	MAX FLG THK	2001-01-12 Date	2213417030		
LM10	500	3	LM	---	19.5T	1	---	---	---	---	---	---	---		R&M Materials Handling Inc.		
LM10	1000	3	LM	4.9S,9.8S	9.8T	1	---								4501 Gateway Blvd, Springfield		
LM10	2000	3	LM	2.4S,4.9S	4.9T	2	---								LM10 LM HOIST		Issue 02/2007