

Dimensions are for reference in estimating only. Use of various modifications may affect overall dimensional outline. Where dimensions are critical, request certified drawings for construction. All dimensions are in millimeters unless otherwise noted.

2213417037

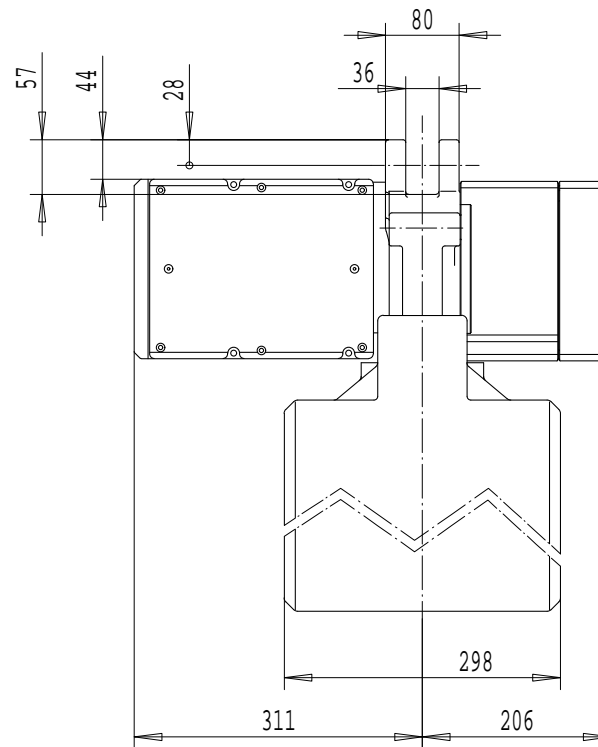
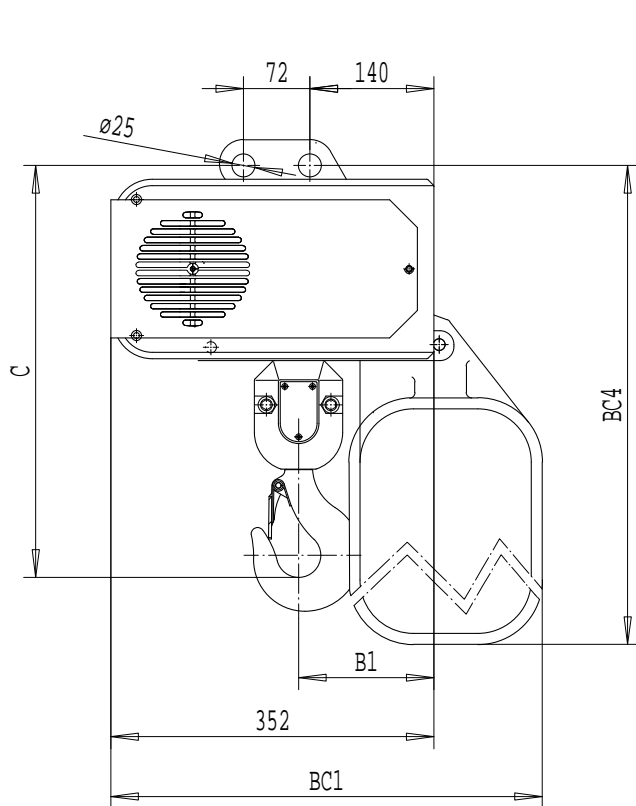

	C	B1	BC1		BC4	
LIFT			<16m	<46m	<16m	<46m
1 FALL	417	146	470	638	634	795
LIFT			<8m	<23m	<8m	<23m
2 FALLS	517	197	470	638	634	795

LOAD MATE CHAIN HOIST MODEL NUMBER							FLG CODE	TROLLEY DIMENSIONS					
FR	CAP Kg	LFT m	SUSP	1 SPEED m/MIN	2 SPEED m/MIN(4:1)	FALL		FLG CODE	FLANGE RANGES	MAX. TD	MAX TW	MIN. WS	MAX FLG THK
LM16	1000	3	LM	-----	19.5T	1	---	---	---	---	---	---	
LM16	1500	3	LM	-----	9.8T	1	---						
LM16	3000	3	LM	-----	4.9T	2	---						

KHSJST Chd	Appd	p_2213417037 File
2001-02-12 Date	2213417037	
R&M MATERIALS HANDLING INC.	R&M Materials Handling Inc. 4501 Gateway Blvd, Springfield LM16 LM HOIST	
	Issue	02/2007