

Dimensions are for reference in estimating only. Use of various modifications may affect overall dimensional outline. Where dimensions are critical, request certified drawings for construction. All dimensions are in inches unless otherwise noted.

2213417030

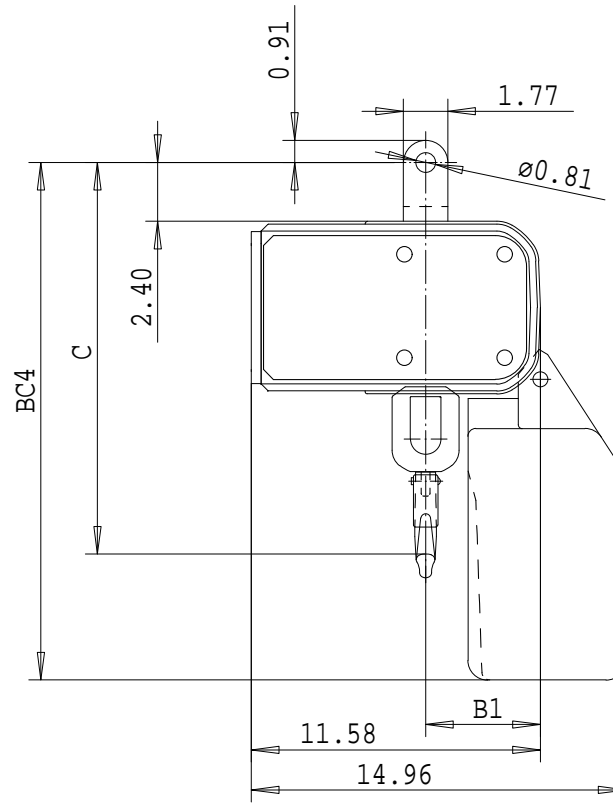
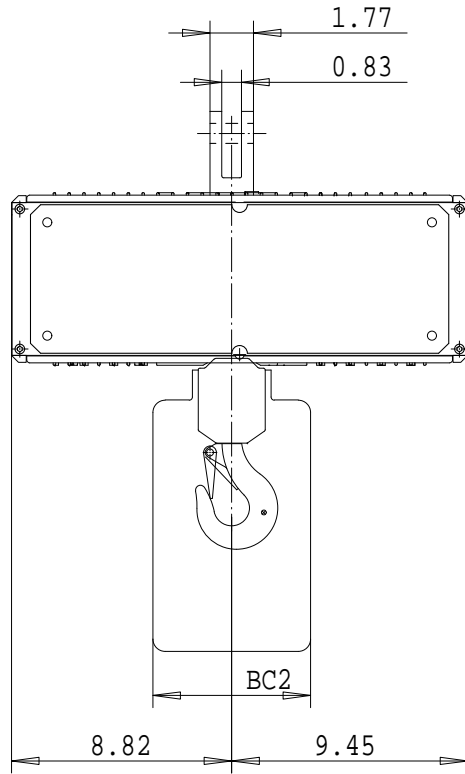

| | C | B1 | BC2 | | | | BC4 | | | |
|---------|-------|------|-------|-------|--------|--------|-------|-------|--------|--------|
| LIFT | --- | --- | <25ft | <50ft | <100ft | <150ft | <25ft | <50ft | <100ft | <150ft |
| 1 FALL | 15.71 | 4.57 | 6.30 | 5.91 | 12.60 | 12.60 | 21.50 | 24.06 | 24.06 | 28.78 |
| LIFT | --- | --- | <13ft | <25ft | <50ft | <75ft | <13ft | <25ft | <50ft | <75ft |
| 2 FALLS | 18.11 | 5.71 | 6.30 | 5.91 | 12.60 | 12.60 | 21.50 | 24.06 | 24.06 | 28.78 |

| LOAD MATE CHAIN HOIST MODEL NUMBER | | | | | | | | TROLLEY DIMENSIONS | | | | | |
|------------------------------------|---------|--------|------|-------------|------------------|------|----------|--------------------|---------------|---------|--------|---------|-------------|
| FR | CAP TON | LFT FT | SUSP | 1 SPEED FPM | 2 SPEED FPM(4:1) | FALL | FLG CODE | FLG CODE | FLANGE RANGES | MAX. TD | MAX TW | MIN. WS | MAX FLG THK |
| LM10 | 1/2 | 10 | LM | --- | 64T | 1 | --- | --- | --- | --- | --- | --- | --- |
| LM10 | 1 | 10 | LM | 16S, 32S | 32T | 1 | --- | | | | | | |
| LM10 | 2 | 10 | LM | 8S, 16S | 16T | 2 | --- | | | | | | |

| | | | |
|------------|--------------------|------------|--|
| KHSJST | Chd | Appd | p_2213417030 |
| 2001-01-12 | Date | 2213417030 | File |
| R&M | MATERIALS HANDLING | INC. | R&M Materials Handling Inc. 4501 Gateway Blvd, Springfield LM10 LM HOIST |
| | | | Issue 02/2007 |