

Dimensions are for reference in estimating only. Use of various modifications may affect overall dimensional outline. Where dimensions are critical, request certified drawings for construction. All dimensions are in inches unless otherwise noted.

2213417038

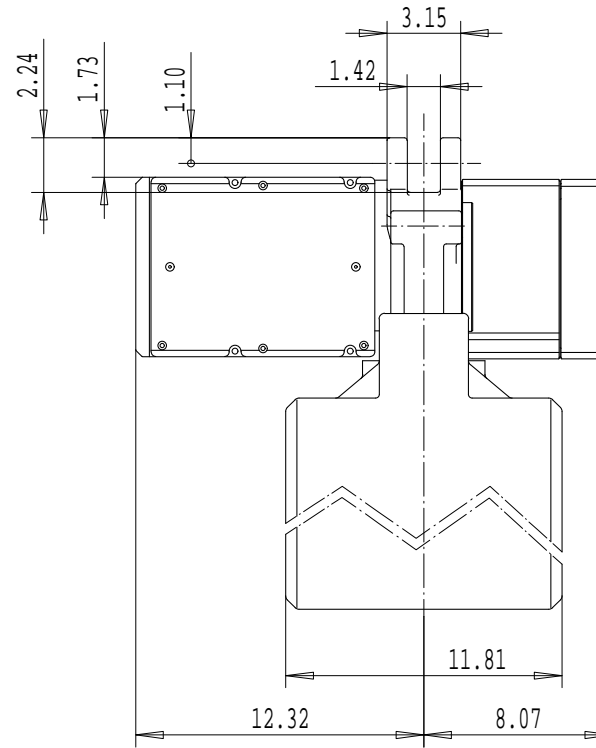
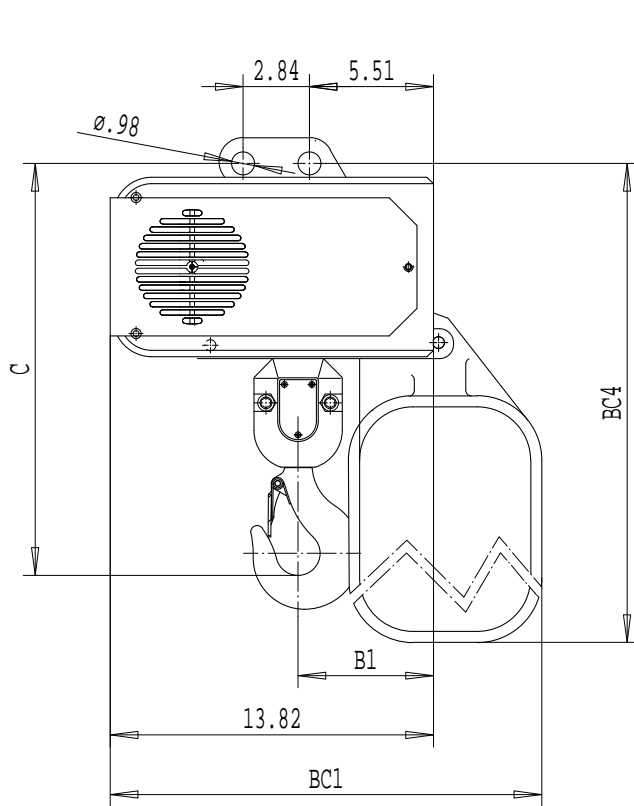

	C	B1	BC1			BC4		
LIFT			<40ft	<100ft	<150ft	<40ft	<100ft	<150ft
1 FALL	17.64	5.75	18.50	25.12	27.87	24.96	31.30	39.17
LIFT			<20ft	<50ft	<75ft	<20ft	<50ft	<75ft
2 FALLS	21.61	7.76	18.50	25.12	27.87	24.96	31.30	39.17

LOAD MATE CHAIN HOIST MODEL NUMBER							TROLLEY DIMENSIONS						
FR	CAP TON	LIFT FT	SUSP	1 SPEED FPM	2 SPEED FPM(4:1)	FALL	FLG CODE	FLG CODE	FLANGE RANGES	MAX. TD	MAX. TW	MIN. WS	MAX. FLG THK
LM25	3	10	LM	---	24T	1	---	---	---	---	---	---	---
LM25	5	10	LM	---	12T	2	---						

KHSJST Chd	Appd	p_2213417038 File
2001-02-12 Date	2213417038	
R&M MATERIALS HANDLING INC.	R&M Materials Handling Inc. 4501 Gateway Blvd, Springfield LM25 LM HOIST	
	Issue	02/2007