

2213417058

Dimensions are for reference in estimating only. Use of various modifications may affect overall dimensional outline. Where dimensions are critical, request certified drawings for construction. All dimensions are in millimeters unless otherwise noted.

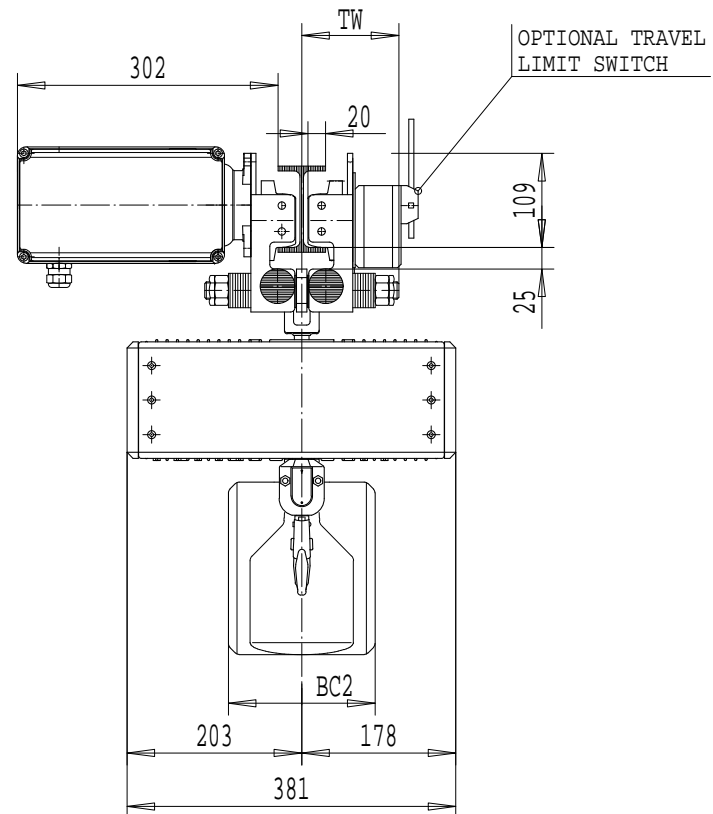
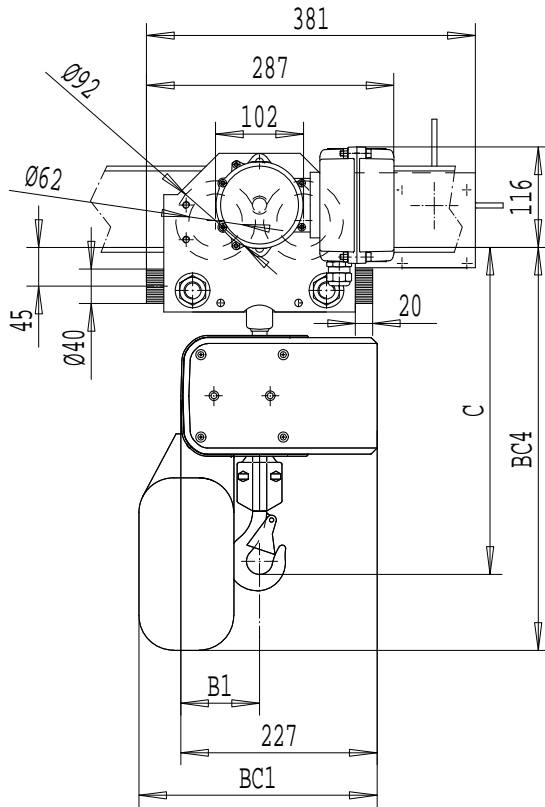

	C	B1	BC1				BC2				BC4			
LIFT			<8m	<16m	<30m	<50m	<8m	<16m	<30m	<50m	<8m	<16m	<30m	<50m
1 FALL	379	91	276	316	311	311	170	160	160	320	470	530	595	595
LIFT			<4m	<8m	<15m	<25m	<4m	<8m	<15m	<25m	<4m	<8m	<15m	<25m
2 FALLS	458	112	276	316	311	311	170	160	160	320	470	530	595	595

LOAD MATE CHAIN HOIST MODEL NUMBER								TROLLEY DIMENSIONS						KHSJST	Appd	p_2213417058
FR	CAP Kg	LIFT m	SUSP	1 SPEED m/MIN	2 SPEED m/MIN(4:1)	FALL	FLG CODE	FLG CODE	FLANGE RANGES	MAX. TD	MAX. TW	MIN. WS	MAX FLG THK	2003-01-28	2213417058	R&M Materials Handling Inc. 4501 Gateway Blvd, Springfield
LM05	250	3	MT	4.9S, 9.8S	9.8T	1	1 - 5	1	58 - 100	---	142	---	20	Date		
LM05	500	3	MT	4.9S, 9.8S	9.8T	1	1 - 5	2	106 - 150	---	167	---	20	R&M		
LM05	500	3	MT	---	4.9T	2	1 - 5	3	155 - 200	---	192	---	20	MATERIALS		
LM05	1000	3	MT	---	4.9T	2	1 - 5	4	206 - 248	---	216	---	20	HANDLING		
								5	260 - 307	---	246	---	20	INC.	LM05 MT, 2SPD TROLLEY	Issue 02/2007