

Dimensions are for reference in estimating only. Use of various modifications may affect overall dimensional outline. Where dimensions are critical, request certified drawings for construction. All dimensions are in inches unless otherwise noted.

2213417062

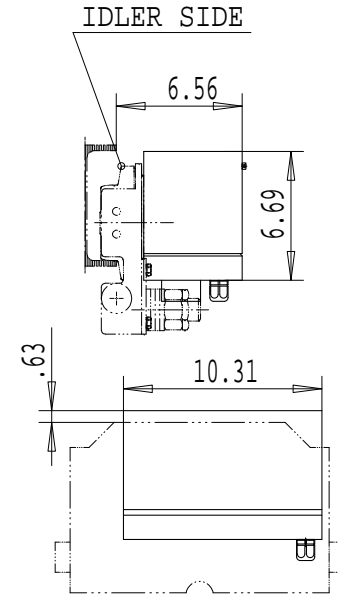
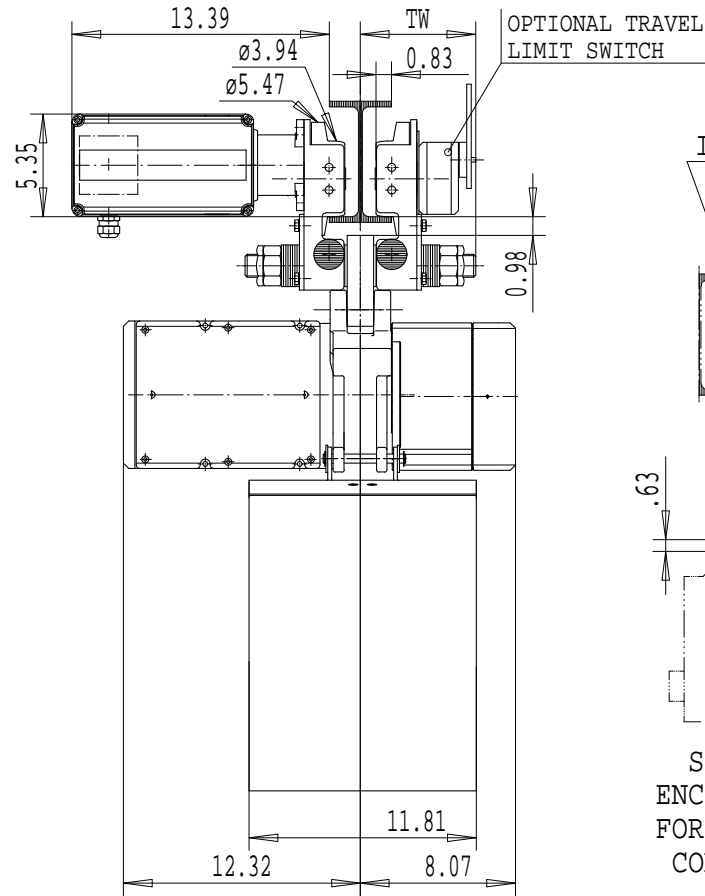
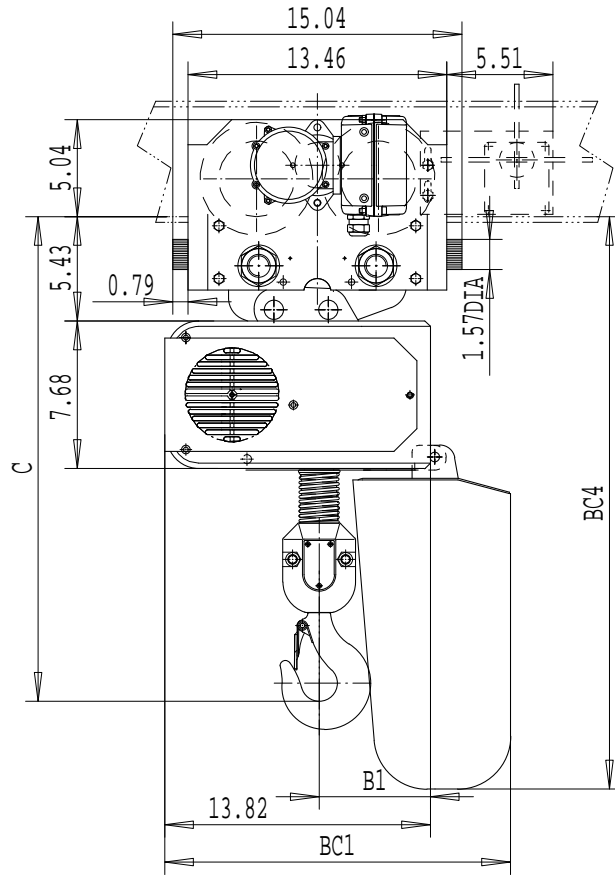

SECOND ELECTRICAL ENCLOSURE IS REQUIRED FOR OPTIONAL INVERTER CONTROLLED TROLLEY.

	C	B1	BC1		BC4	
LIFT	---	---	<40ft	<100ft	<40ft	<100ft
1 FALL	25.16	5.79	17.99	24.80	29.80	36.14

FOR LIFTS OVER 100 FT, SEE PAGE 2 OF 2

LOAD MATE CHAIN HOIST MODEL NUMBER							TROLLEY DIMENSIONS						
FR	CAP TON	LFT FT	SUSP	1 SPEED FPM	2 SPEED FPM(4:1)	FALL	FLG CODE	FLG CODE	FLANGE RANGES	MAX. TD	MAX TW	MIN. WS	MAX FLG THK
LM20	2	10	MT	-----	32T	1	1 - 4	1	3.23 - 5.39	---	6.00	---	.79
								2	5.51 - 7.48	---	6.99	---	.79
								3	7.80 - 9.76	---	8.17	---	.79
								4	10.24-12.20	---	9.35	---	.79

Chd	KHSJST	p_2213417062
2003-03-07	Appd	File
Date	2213417062	
R&M	R&M Materials Handling Inc.	
MATERIALS	4501 Gateway Blvd, Springfield	
HANDLING	LM20 MT	Issue
INC.		02/2007