

2213417007

Dimensions are for reference in estimating only. Use of various modifications may affect overall dimensional outline. Where dimensions are critical, request certified drawings for construction. All dimensions are in millimeters unless otherwise noted.

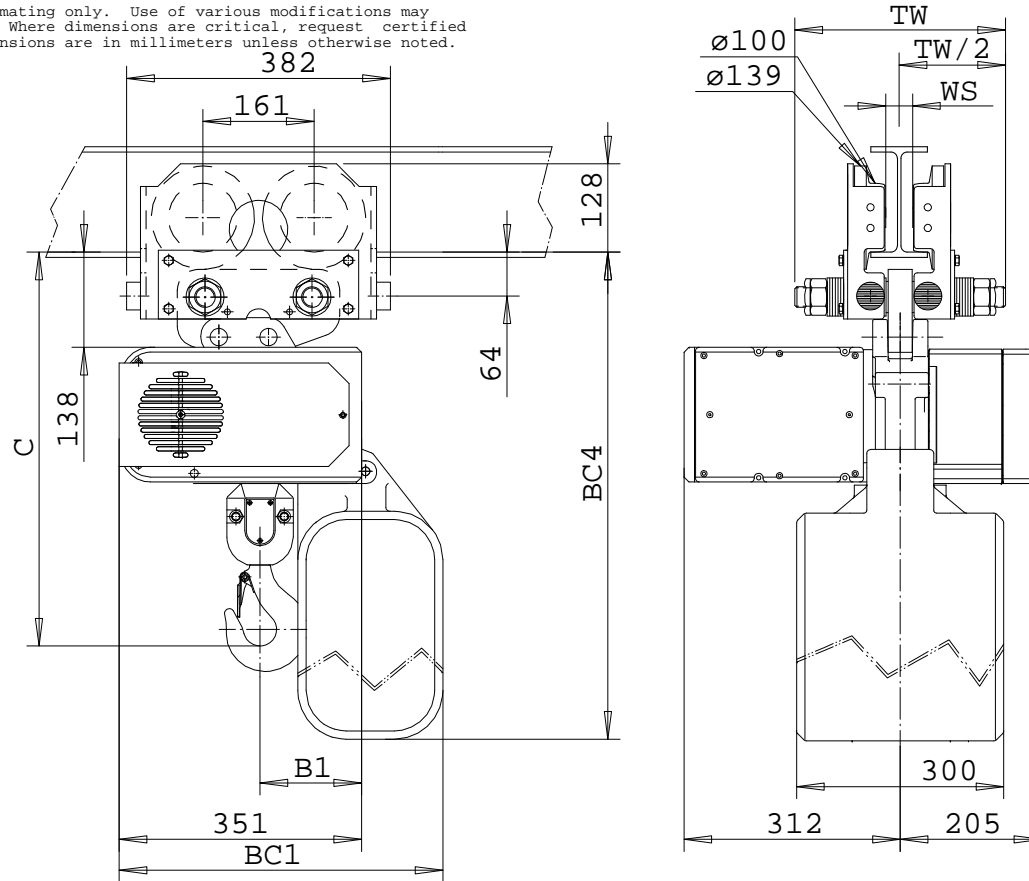

	C	B1	BC1			BC4		
LIFT	---	---	<16m	<30m	<46m	<16m	<30m	<46m
1 FALL	540	147	469	639	709	757	918	1118
LIFT	---	---	<8m	<15m	<23m	<8m	<15m	<23m
2 FALLS	640	196	469	639	709	757	918	1118

LOAD MATE CHAIN HOIST MODEL NUMBER								TROLLEY DIMENSIONS						Chd	Appd	p_2213417007 File	
FR	CAP Kg	LFT m	SUSP	1 SPEED m/MIN	2 SPEED m/MIN(4:1)	FALL	FLG CODE	FLG CODE	FLANGE RANGES	MAX. TD	MAX TW	MIN. WS	MAX FLG THK	2000-10-17 Date	2213417007		
LM16	1000	3	PT	-----	19.5T	1	1 - 4	1	82-137	---	305	38	22		R&M MATERIALS HANDLING INC.		
LM16	1500	3	PT	-----	9.8T	1	1 - 4	2	140-190	---	365	96	22			4501 Gateway Blvd, Springfield	
LM16	3000	3	PT	-----	4.9T	2	1 - 4	3	198-248	---	425	154	22				
								4	260-310	---	492	216	22			LM16 PT HOIST	Issue 02/2007