

Dimensions are for reference in estimating only. Use of various modifications may affect overall dimensional outline. Where dimensions are critical, request certified drawings for construction. All dimensions are in inches unless otherwise noted.

\*\*see outline drawing 2213417054 for dimensions when capacity is 1/2 ton or less.

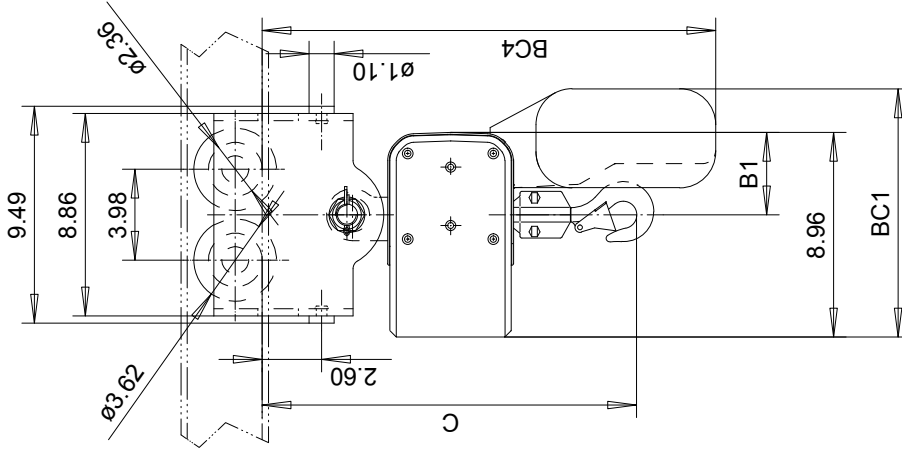
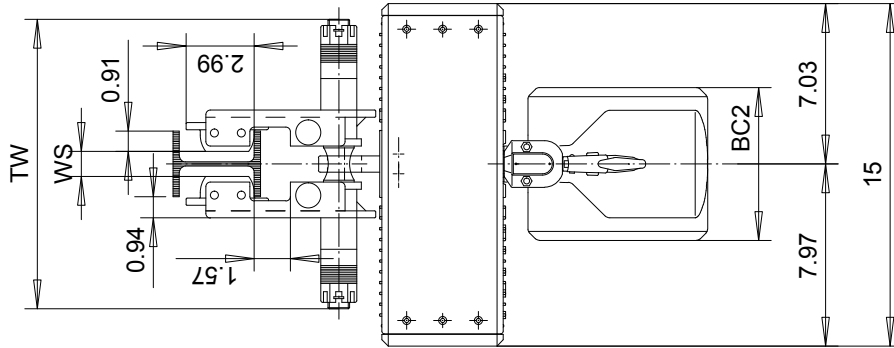

Minimum radius curve: 39.4 in.

C	LIFT	B1	BC1			BC2			BC4					
			< 13ft	< 25ft	< 50ft	< 13ft	< 25ft	< 50ft	< 13ft	< 25ft	< 50ft	< 75ft		
2 FALLS	20 3/4"	4.41	10.87	12.44	12.24	12.24	6.30	5.91	12.60	12.60	20.00	22.36	24.92	24.92

LOADMATE CHAIN HOIST MODEL NUMBER				TROLLEY DIMENSIONS				KHSJUST						
FR	CAP TON	LIFT FT	SUSP	1 SPEED FPM	2 SPEED FPM(4:1)	FALL	FLG CODE	MAX TD	MAX TW	MIN WS	MAX FLG THK	Chd	Appd	File
LM05	1	10	PT	---	16T	2	1,2	**	12.68	0.75	1.38	2003-01-20	2213417055	p_2213417055
								**	16.93	6.06	1.38	R&M	R&M Materials Handling Inc.	
												MATERIALS HANDLING	4501 Gateway Blvd, Springfield	
												INC.	LM05 PT HOIST	Issue 05/2010