

2213417023

Dimensions are for reference in estimating only. Use of various modifications may affect overall dimensional outline. Where dimensions are critical, request certified drawings for construction. All dimensions are in inches unless otherwise noted.

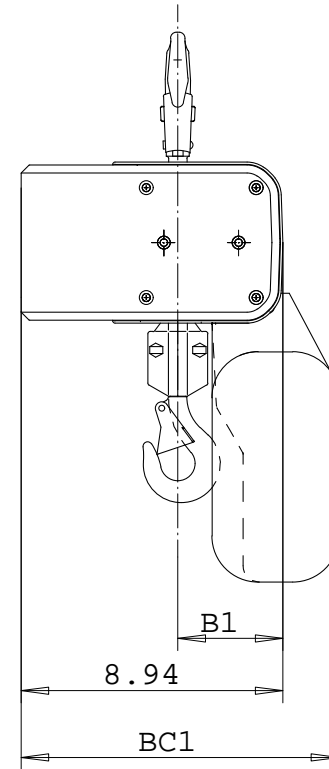
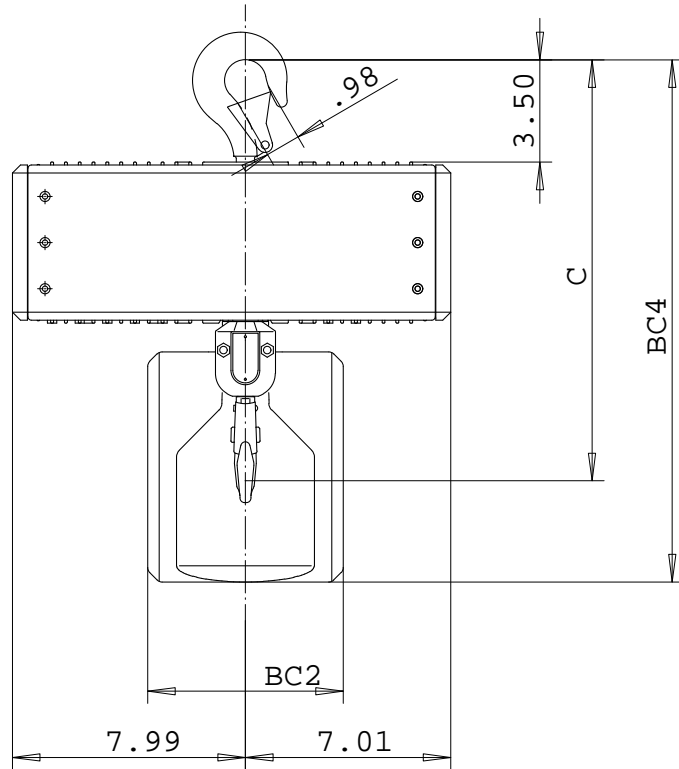

| | C | B1 | BC1 | | | | BC2 | | | | BC4 | | | |
|---------|-------|------|-------|-------|--------|--------|-------|-------|--------|--------|-------|-------|--------|--------|
| LIFT | | | <25ft | <50ft | <100ft | <150ft | <25ft | <50ft | <100ft | <150ft | <25ft | <50ft | <100ft | <150ft |
| 1 FALL | 16.50 | 3.62 | 11.89 | 13.39 | 13.39 | 13.39 | 6.61 | 6.61 | 6.02 | 12.64 | 17.87 | 20.39 | 22.99 | 22.99 |
| LIFT | | | <13ft | <25ft | <50ft | <75ft | <13ft | <25ft | <50ft | <75ft | <13ft | <25ft | <50ft | <75ft |
| 2 FALLS | 18.39 | 4.49 | 11.89 | 13.39 | 13.39 | 13.39 | 6.61 | 6.61 | 6.02 | 12.64 | 17.87 | 20.39 | 22.99 | 22.99 |

| LOAD MATE CHAIN HOIST MODEL NUMBER | | | | | | | | TROLLEY DIMENSIONS | | | | | |
|------------------------------------|---------|---------|------|-------------|------------------|------|----------|--------------------|---------------|---------|---------|---------|--------------|
| FR | CAP TON | LIFT FT | SUSP | 1 SPEED FPM | 2 SPEED FPM(4:1) | FALL | FLG CODE | FLG CODE | FLANGE RANGES | MAX. TD | MAX. TW | MIN. WS | MAX. FLG THK |
| LM05 | 1/4 | 10 | THX | 16S, 32S | 32T | 1 | --- | --- | --- | --- | --- | --- | --- |
| LM05 | 1/2 | 10 | THX | 16S, 32S | 32T | 1 | --- | | | | | | |
| LM05 | 1/2 | 10 | THX | --- | 16T | 2 | --- | | | | | | |
| LM05 | 1 | 10 | THX | --- | 16T | 2 | --- | | | | | | |

| | | |
|-----------------------|--------------------------------|----------------------|
| Chd | Appd | p_2213417023 File |
| 2000-11-03 Date | 2213417023 | |
| R&M | R&M Materials Handling Inc. | |
| MATERIALS HANDLING | 4501 Gateway Blvd, Springfield | |
| INC. | LM05 THX HOIST | Issue 02/2007 |