

# DOUBLE GIRDER, MEDIUM, 4 PART SINGLE

Hoist type:

SX2 041..D0

SX3 041..D0

SI-50Hz

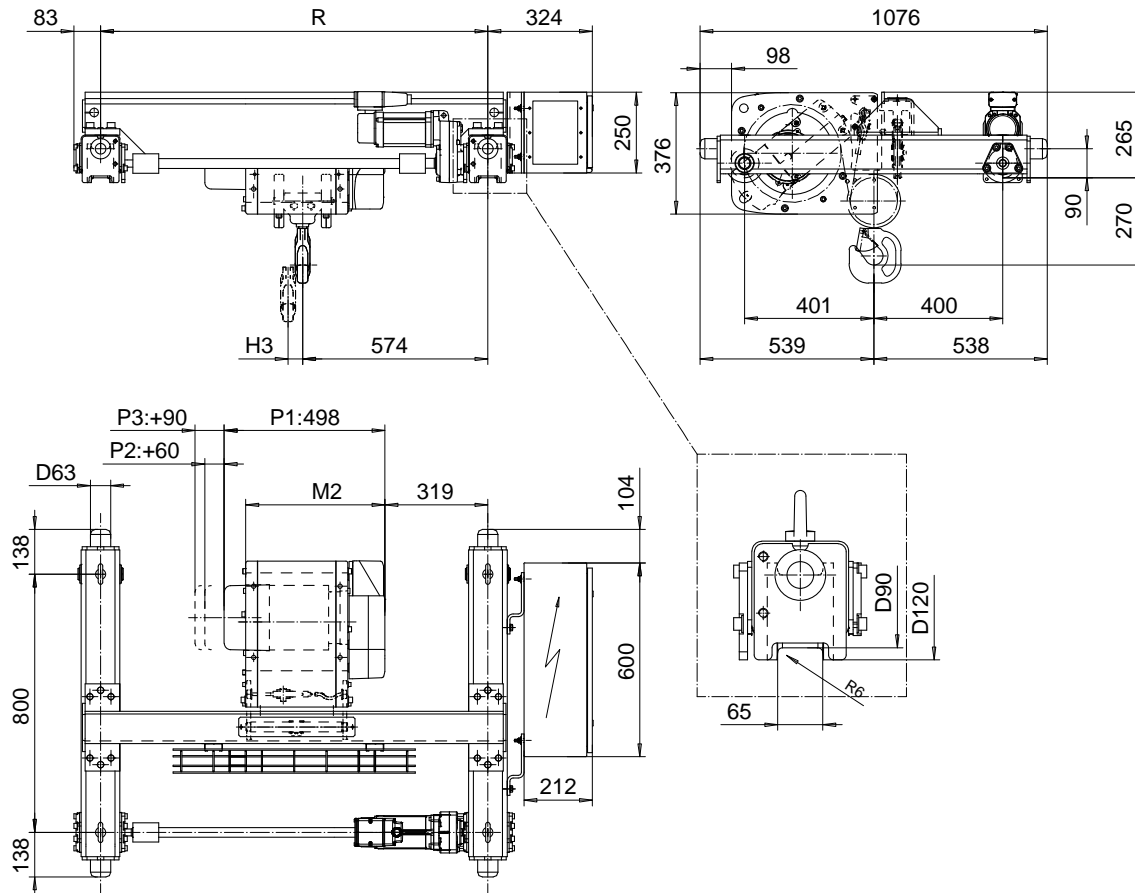

Load (kg)	Class Fem/ISO	Hoisting speed (m/min)			
		Gear+Motor code:			
		F+P1	F+P2	G+P2	H+P3
1600	3m/M6	5/0.8	5/0.8	6.3/1.1	8/1.3
2000	2m/M5	5/0.8	5/0.8	6.3/1.1	8/1.3
2500	3m/M6	-	5/0.8	6.3/1.1	8/1.3
3200	2m/M5	-	5/0.8	6.3/1.1	8/1.3
+ weight (kg):		-	10	10	13

HOL (m)	Length code	M2 (mm)	H3 (mm)	min R (mm)	Weight (kg)
6	A	431	45	1200	225
9.5	C	561	72	1200	235

Note: minR is minimum rail gauge when second brake is supplied  
Standard rail gauges are 1200, 1400, 1700, and 2000 mm.

This document is the absolute property of R&M Materials Handling, Inc. This document must not be copied without the written permission of R&M Materials Handling, Inc. The contents thereof must not be disclosed to a third party nor be used for any unauthorized purpose. Contravention will be prosecuted.

Design	Chk	Appd	Ref Drawing	QA-M-04
Date	TROLLEY; DOUBLE GIRDER			1:10
SLE/ME/CE Owner Dept	MEDIUM, 4 ROPE FALLS			
R&M MATERIALS HANDLING, INC. RISQ & CONE PRODUCTS SHEPHERD, TEX	D002081-A			Drawn 5