

DOUBLE GIRDER, MEDIUM, 2 PART SINGLE

Hoist type:

SX4 021...D0

SI-50Hz

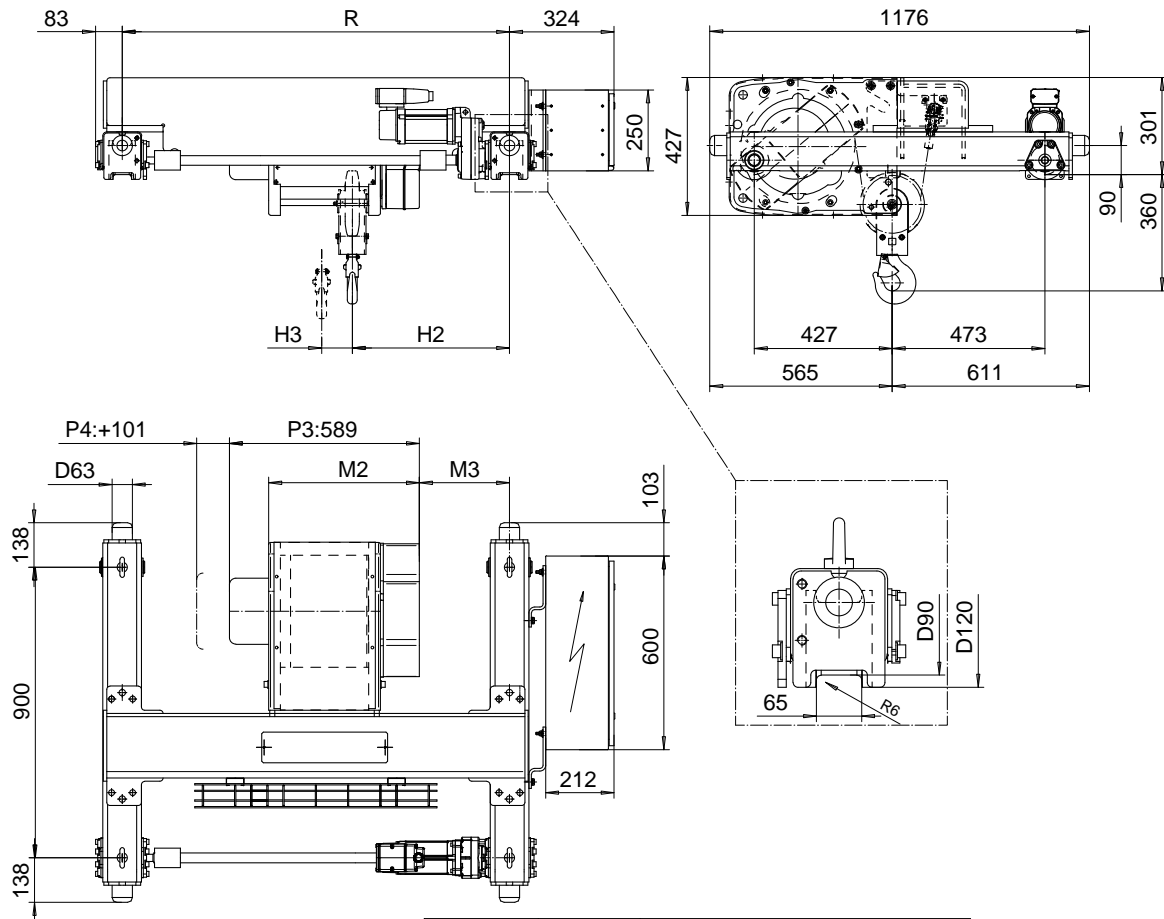

Load (kg)	Class Fem/IS	Hoisting speed (m/min)		
		Gear+Motor code:		
		E+P3	F+P3	H+P4
1600	3m/M6	8/1.3	10/1.7	16/2.7
2000	3m/M6	8/1.3	10/1.7	16/2.7
2500	2m/M5	8/1.3	-	-
+ weight (kg):		-	-	20

HOL (m)	Length code	M2 (mm)	M3 (mm)	H2 (mm)	H3 (mm)	min R (mm)	Weight (kg)
12	B	467	280	487	95	1200	310
18	C	567	280	487	144	1200	320
24	D	667	352	559	193	1400	335
30	E	787	352	559	252	1400	350

Note: min R is minimum rail gauge when second brake is supplied
Standard rail gauges are 1200, 1400, 1700, and 2000 mm

This document is the absolute property of R&M Materials Handling, Inc. This document must not be copied without the written permission of R&M Materials Handling, Inc. The contents thereof must not be disclosed to a third party nor be used for any unauthorized purpose. Contravention will be prosecuted.

Design	Chk	Appd	Ref Drawing	QB-M-02
Date	TROLLEY; DOUBLE GIRDER			1:10 Tol:Min
SLE/REN/01 Owner Dept	MEDIUM, 2 ROPE FALLS			
R&M MATERIALS HANDLING, INC. RISQ & CONE DIVISION SHELDON, ILL.	D002088-A			Drawn 4