

**DOUBLE GIRDER, HIGH CONNECTION, 4 PART SINGLE**  
**Hoist type:**  
**SX4 041...DH**

SI-50Hz

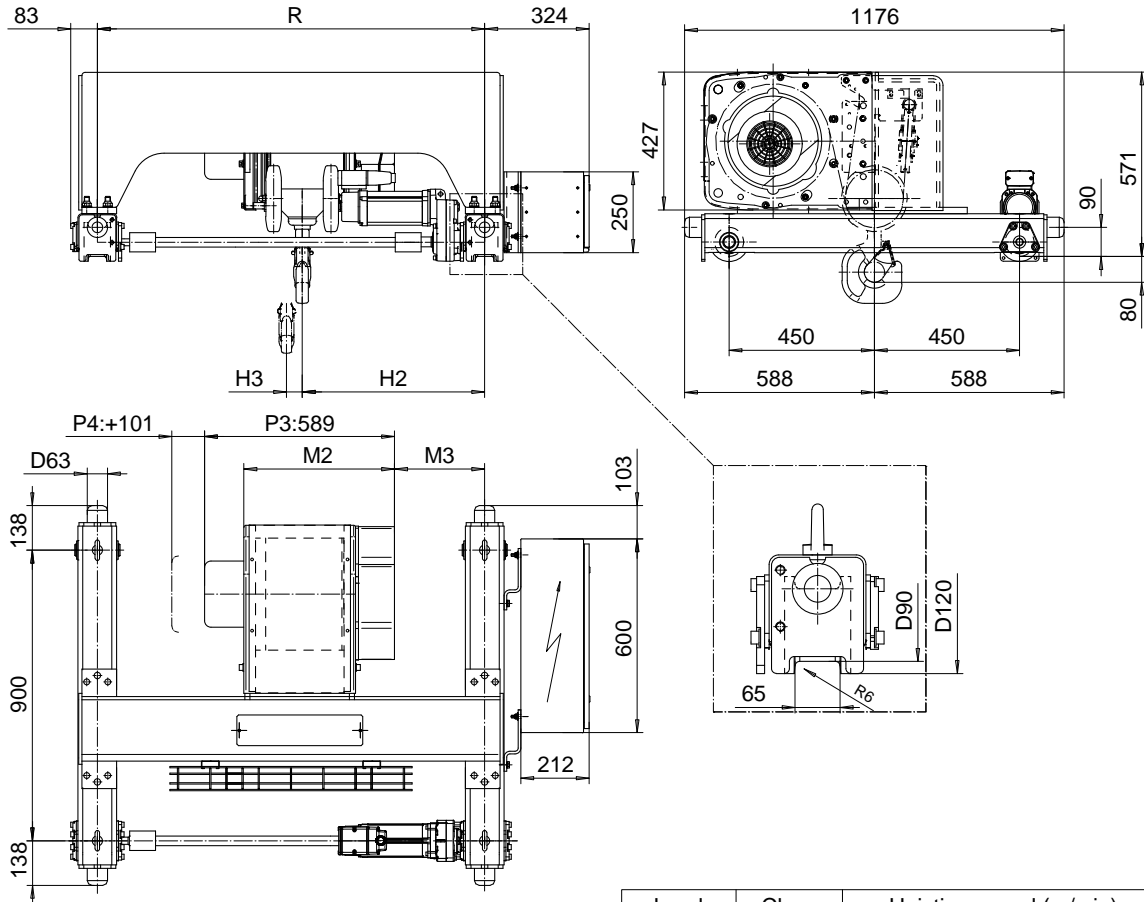

Load (kg)	Class Fem/ISO	Hoisting speed (m/min)		
		Gear+Motor code:		
		E+P3	F+P3	H+P4
3200	3m/M6	4/0.7	5/0.8	8/1.3
4000	3m/M6	4/0.7	5/0.8	8/1.3
5000	2m/M5	4/0.7	5/0.8	8/1.3
+ weight (kg):		-	-	20

HOL (m)	Length code	M2 (mm)	M3 (mm)	H2 (mm)	H3 (mm)	min R (mm)	Weight (kg)
6	B	467	130	415	49	900	325
9	C	567	130	415	74	900	335
12	D	667	102	387	99	900	355
15	E	787	252	537	129	1200	375

Note: minR is minimum rail gauge when second brake is supplied  
 Standard rail gauges are 900, 1200, 1400, 1700, and 2000 mm

This document is the absolute property of R&M Materials Handling, Inc. This document must not be copied without the written permission of R&M Materials Handling, Inc. The contents thereof must not be disclosed to a third party nor be used for any unauthorized purpose. Contravention will be prosecuted.

Design	Chd	Appd	Ref Drawing	QB-H-04
Date	TROLLEY; DOUBLE GIRDER			1:10 Folder
SLEQENGL Owner Dept	HIGH, 4 ROPE FALLS			
R&M MATERIALS HANDLING, INC. HOIST & CRANE PRODUCTS SHELTONVILLE, OHIO	D002230-A			Issue 4