

DOUBLE GIRDER, HIGH CONNECTION, 2 PART SINGLE
Hoist type:
SX5 021...DH

SI-50Hz

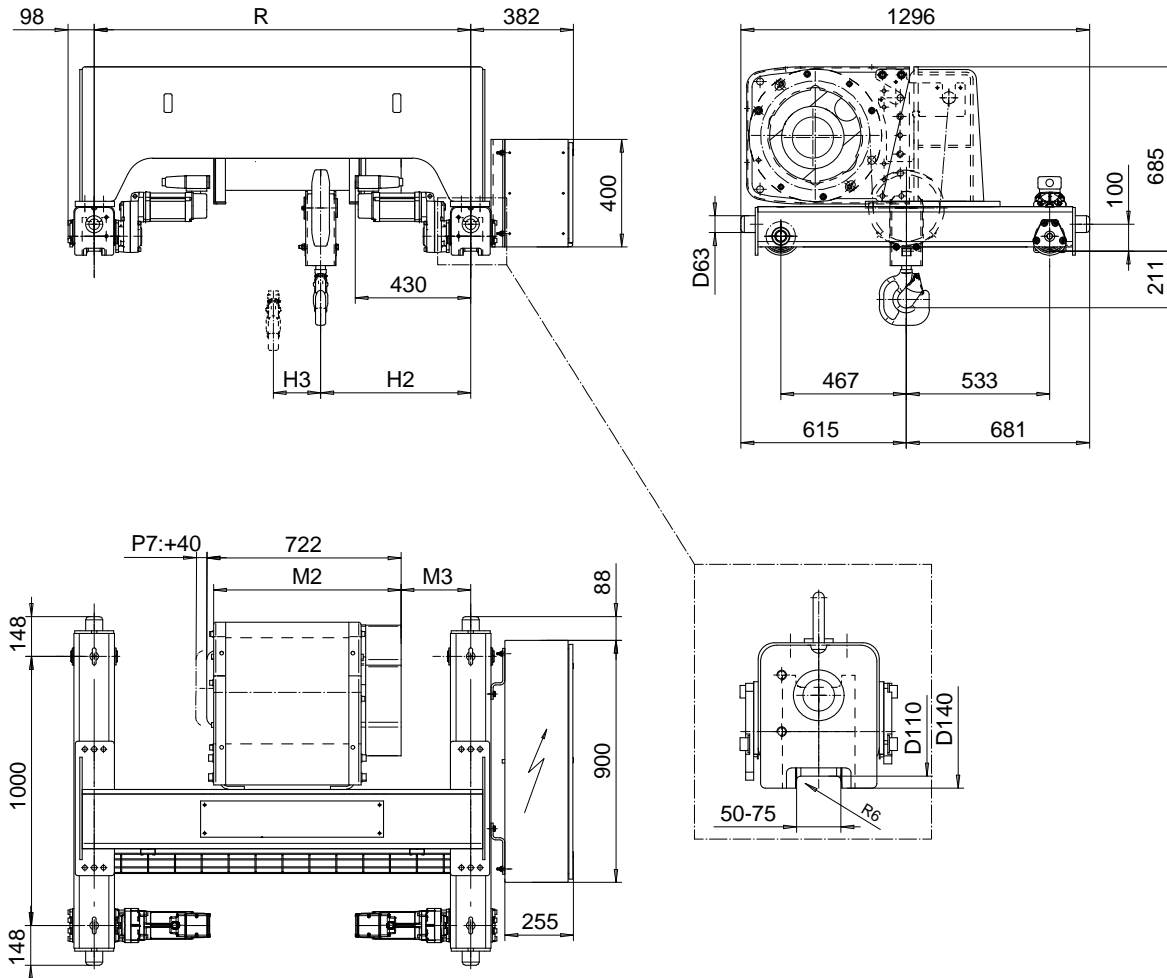

Load (kg)	Class Fem/ISO	Hoisting speed (m/min)			
		Gear+Motor code:			
		E+P5	F+P5	H+P6	J+P7
4000	3m/M6	8/1.3	10/1.7	16/2.7	20/3.3
5000	2m/M5	8/1.3	10/1.7	16/2.7	20/3.3
+ weight (kg):		-	-	30	40

HOL	Length (m)	M2 code	M3 (mm)	H2 (mm)	H3 (mm)	min R (mm)	Weight (kg)
18	D	697	159	458	176	1200	665
24	E	817	159	458	235	1200	690
32	F	967	122	421	309	1200	715
40	G	1157	372	671	403	1700	795

Note: minR is minimum rail gauge when second brake is supplied
 Standard rail gauges are 1200, 1400, 1700, and 2000 mm

This document is the absolute property of R&M Materials Handling, Inc. This document must not be copied without the written permission of R&M Materials Handling, Inc. The contents thereof must not be disclosed to a third party nor be used for any unauthorized purpose. Contravention will be prosecuted.

ETTATA Design	ETTAV Chd	Appd	Ref Drawing	QC-H-02
2002-10-14 Date	TROLLEY; DOUBLE GIRDER			1 of 12 Folder
SLEQDOCV Owner Dept	HIGH, 2 ROPE FALLS			
R&M MATERIALS HANDLING, INC. 5000 S. GARDNER BLVD. SPRINGFIELD, OHIO	D002238-A			Issue 4