

DOUBLE GIRDER, HIGH CONNECTION, 4 PART SINGLE

Hoist type:

SX5 041...DH

SI-50Hz

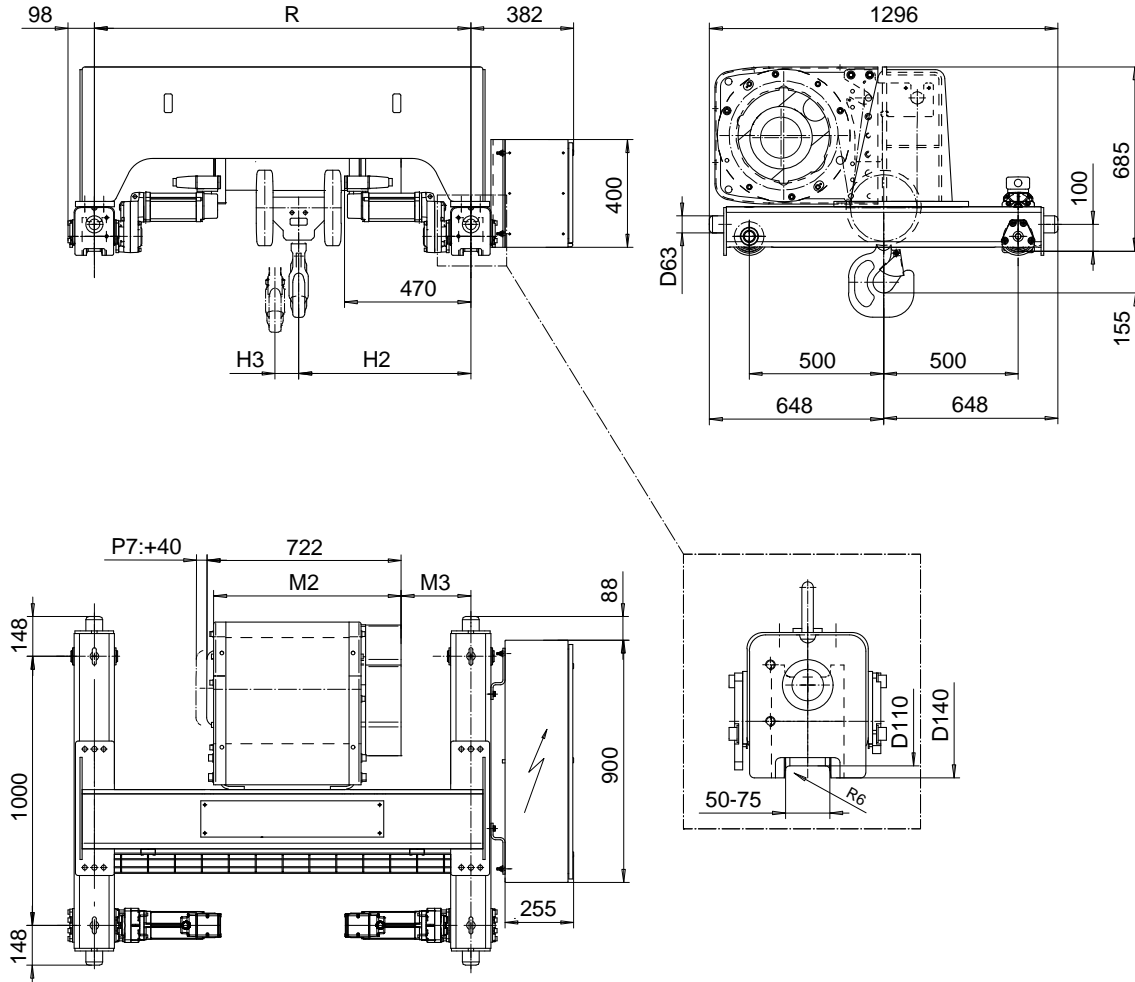

Load (kg)	Class Fem/ISO	Hoisting speed (m/min)			
		Gear+Motor code:			
		E+P5	F+P5	H+P6	J+P7
6300	3m/M6	4/0.7	5/0.8	8/1.3	10/1.7
8000	3m/M6	4/0.7	5/0.8	8/1.3	10/1.7
10000	2m/M5	4/0.7	5/0.8	8/1.3	10/1.7
+ weight (kg):		-	-	30	40

HOL (m)	Length code	M2 (mm)	M3 (mm)	H2 (mm)	H3 (mm)	min R (mm)	Weight (kg)
9	D	697	159	540	88	1200	685
12	E	817	159	540	118	1200	710
16	F	967	122	503	156	1200	735
20	G	1157	372	753	204	1700	815

Note: minR is minimum rail gauge when second brake is supplied
Standard rail gauges are 1200, 1400, 1700, and 2000 mm

This document is the absolute property of R&M Materials Handling, Inc. This document must not be copied without the written permission of R&M Materials Handling, Inc. The contents thereof must not be disclosed to a third party nor be used for any unauthorized purpose. Contravention will be prosecuted.

ETTATA Design	ETTAV Chd	Appd	Ref Drawing	QC-H-04
2002-10-14 Date	TROLLEY; DOUBLE GIRDER			1 of 12 Folder
SLEQDOCV Owner Dept	HIGH, 4 ROPE FALLS			
R&M MATERIALS HANDLING, INC. HOIST & CRANE PRODUCTS SHELLEBURGH, OHIO	D002240-A			Issue 4