

DOUBLE GIRDER, HIGH CONNECTION, 2 PART SINGLE

Hoist type:

SX4 021...DH

SI-60Hz

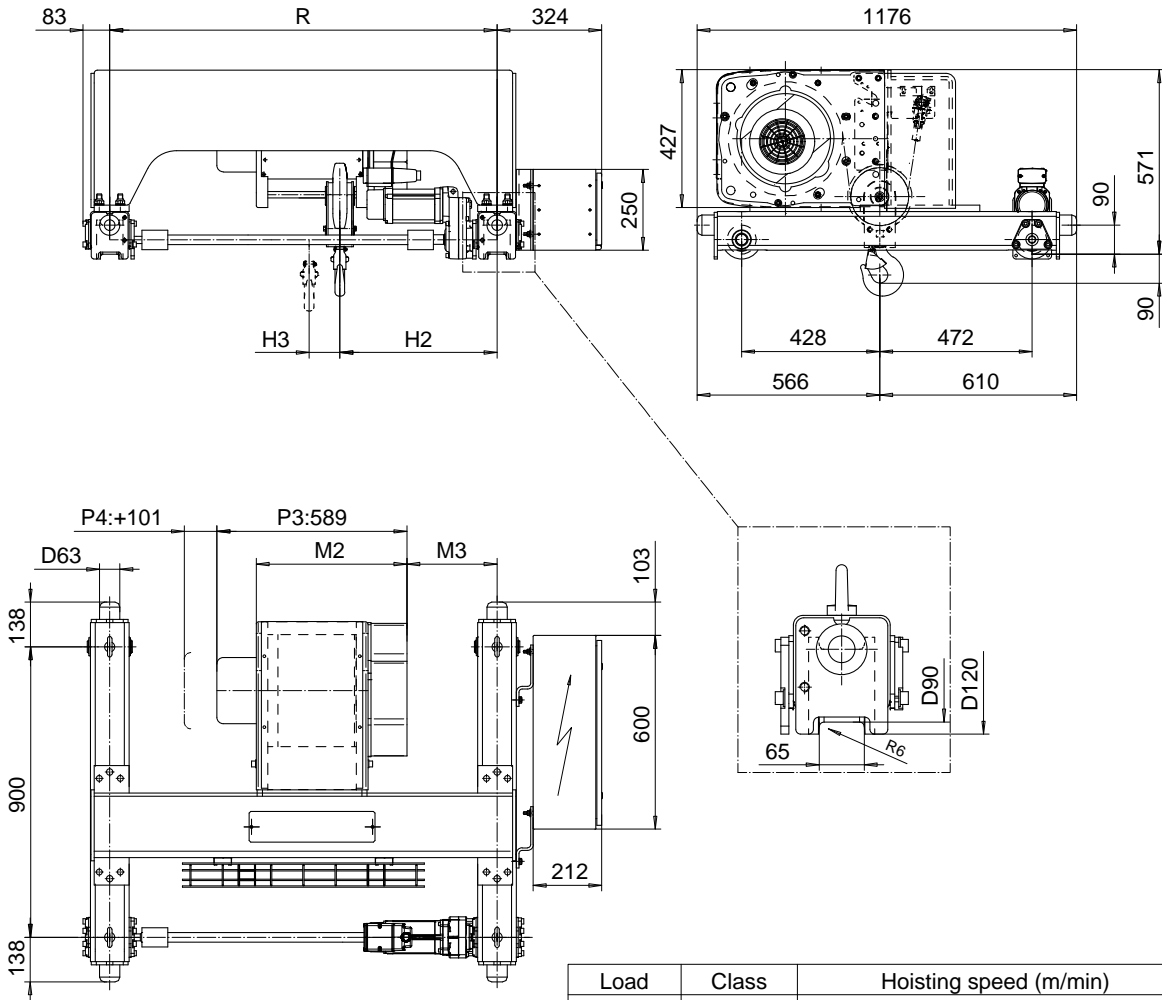

Load (kg)	Class Fem/ISO	Hoisting speed (m/min)		
		Gear+Motor code:		
		E+P3	F+P3	H+P4
1600	3m/M6	9.5/1.6	12/2	19/3.2
2000	3m/M6	9.5/1.6	12/2	19/3.2
2500	2m/M5	9.5/1.6	12/2	19/3.2
+ weight (kg):		-	-	20

HOL (m)	Length code	M2 (mm)	M3 (mm)	H2 (mm)	H3 (mm)	min R (mm)	Weight (kg)
12	B	467	130	337	95	900	321
18	C	567	130	337	144	900	331
24	D	667	102	309	193	900	346
30	E	787	252	459	252	1200	367

Note: minR is minimum rail gauge when second brake is supplied
 Standard rail gauges are 900, 1200, 1400, 1700, and 2000 mm

This document is the absolute property of R&M Materials Handling, Inc. This document must not be copied without the written permission of R&M Materials Handling, Inc. The contents thereof must not be disclosed to a third party nor be used for any unauthorized purpose. Contravention will be prosecuted.

Design	Chd	Appd	Ref Drawing	QB-H-02
Date	TROLLEY; DOUBLE GIRDER			1-130 Folder
SLEQENGL Owner Dept	HIGH, 2 ROPE FALLS			
R&M	D002229-A			Issue 4