

DOUBLE GIRDER, MEDIUM, 8 PART SINGLE
Hoist type:
SX4 081...D0

SI-60Hz

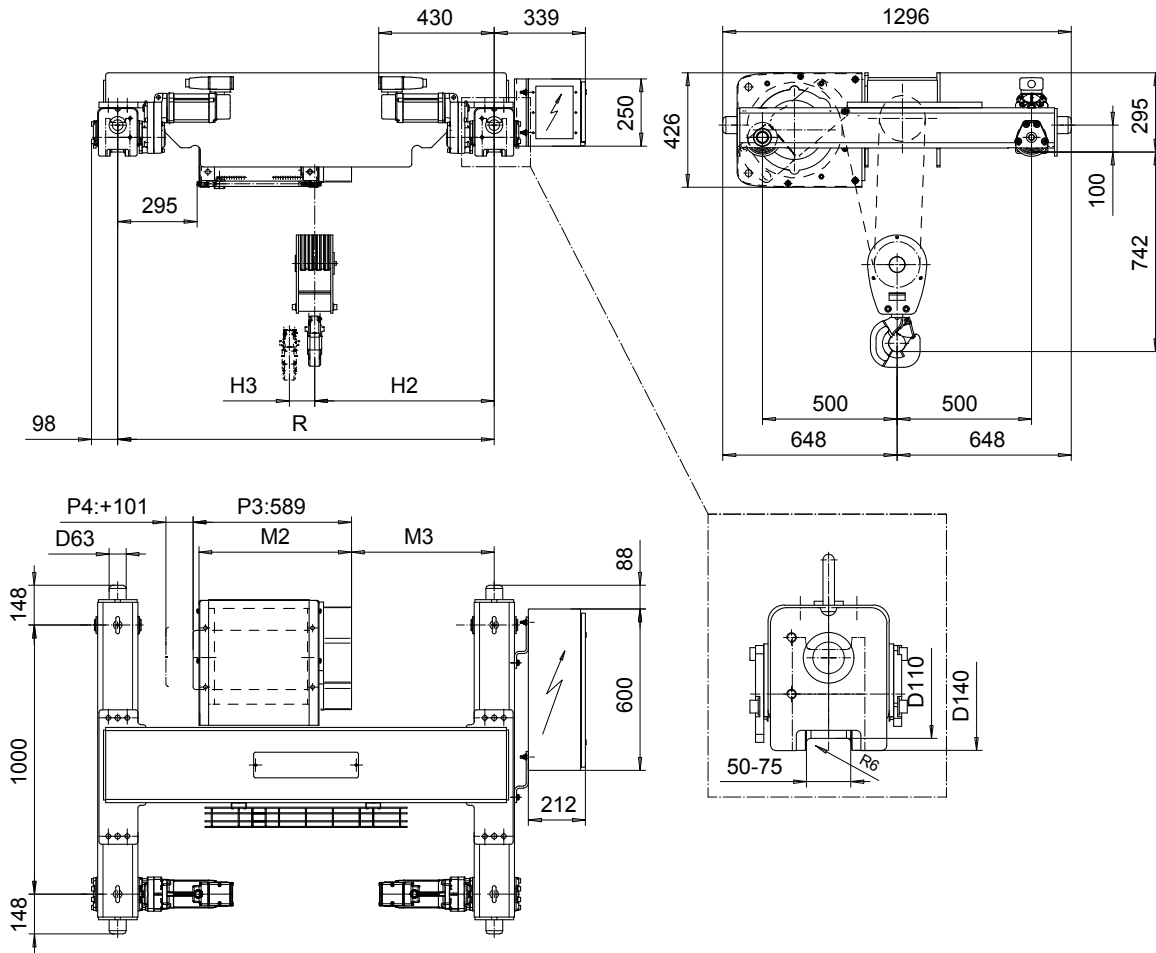

Load (kg)	Class Fem/ISO	Hoisting speed (m/min)	
		Gear+Motor code:	
		F+P3	H+P4
8000	2m/M5	3/0.5	4.8/0.8
10000	1Am/M4	3/0.5	4.8/0.8
+ weight (kg):		-	20

HOL	Length (m)	M2 code	M3 (mm)	H2 (mm)	H3 (mm)	min R (mm)	Weight (kg)
4.5	C	567	531	668	37	1400	655
6	D	667	681	818	49	1700	700
7.5	E	787	831	968	64	2000	740

Note: minR is minimum rail gauge when second brake is supplied
 Standard rail gauges are 1400, 1700, and 2000 mm

This document is the absolute property of R&M Materials Handling, Inc. This document must not be copied without the written permission of R&M Materials Handling, Inc. The contents thereof must not be disclosed to a third party nor be used for any unauthorized purpose. Contravention will be prosecuted.

ETFPAL Design 2002-08-28 Date	ETFPAL Chd Appd	Ref Drawing	QB-M-08
SLEQDCV Owner Dept	TROLLEY; DOUBLE GIRDER MEDIUM, 8 ROPE FALLS		1 of 12 Folder
R&M R&M MATERIALS HANDLING, INC. HOIST & CRANE PRODUCTS SHEWAN/UMESDALE, OHIO	D002103-A		Issue 6