

DOUBLE GIRDER, HIGH CONNECTION, 8 PART SINGLE
Hoist type:
SX4 081...DH

SI-60Hz

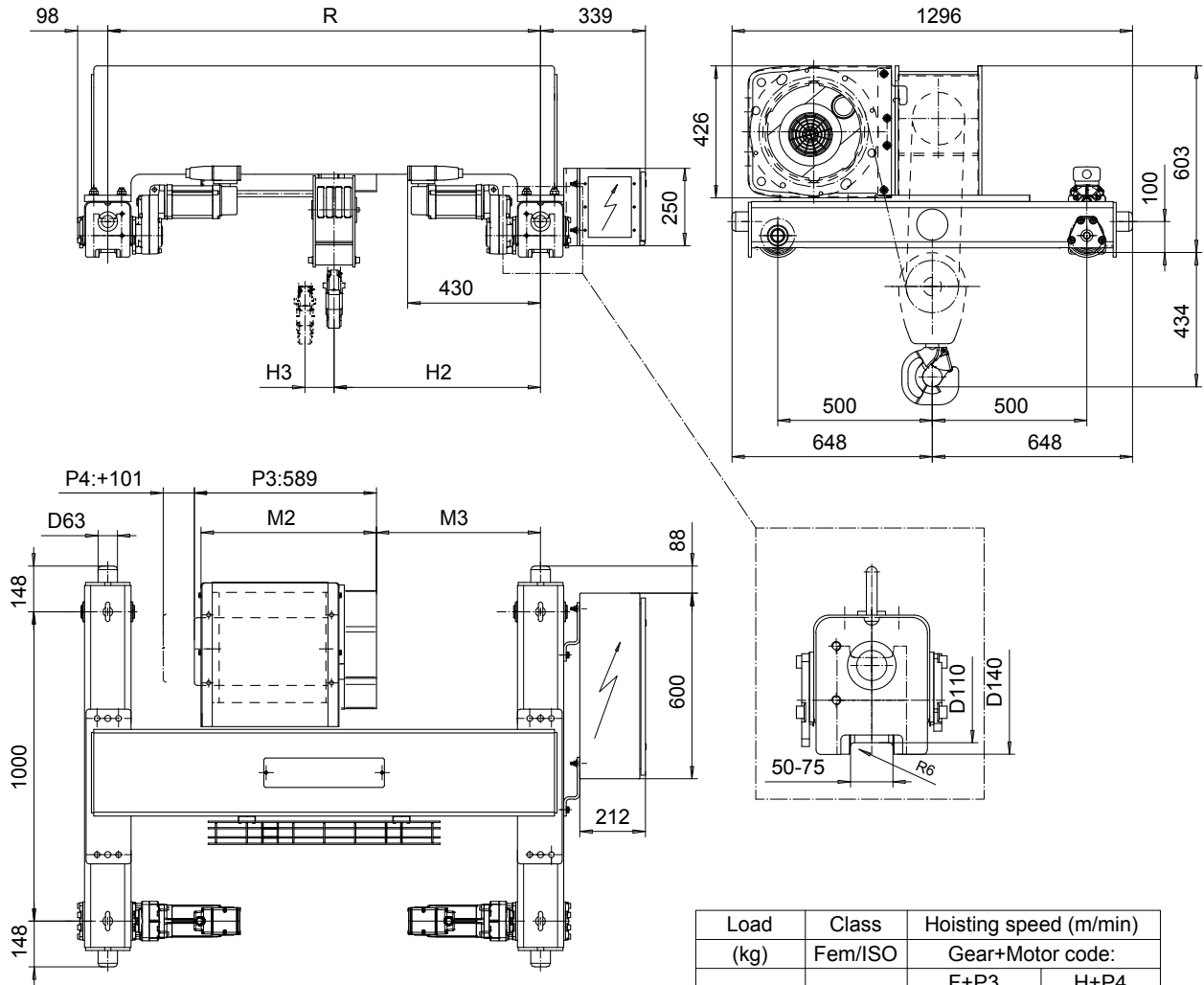

Load (kg)	Class Fem/ISO	Hoisting speed (m/min)	
		F+P3	H+P4
8000	2m/M5	3/0.5	4.8/0.8
10000	1Am/M4	3/0.5	4.8/0.8
+ weight (kg):		-	20

HOL (m)	Length code	M2 (mm)	M3 (mm)	H2 (mm)	H3 (mm)	min R (mm)	Weight (kg)
4.5	C	567	431	568	37	1200	680
6	D	667	431	568	49	1200	695
7.5	E	787	531	668	64	1400	735

Note: minR is minimum rail gauge when second brake is supplied
 Standard rail gauges are 900, 1200, 1400, 1700, and 2000 mm

This document is the absolute property of R&M Materials Handling, Inc. This document must not be copied without the written permission of R&M Materials Handling, Inc. The contents thereof must not be disclosed to a third party nor be used for any unauthorized purpose. Contravention will be prosecuted.

ETTATA Design	ETTPAL Chd	Appd	Ref Drawing	QB-H-08
2002-10-14 Date	TROLLEY; DOUBLE GIRDER HIGH, 8 ROPE FALLS			2:10 Folder
SLEQDCV Owner Dept	R&M SAN MATEO CALIFORNIA, INC. HOIST & CRANE PRODUCTS SHERWOOD, OHIO			Issue 5
D002237-A				