

**DOUBLE GIRDER, HIGH CONNECTION, 2 PART DOUBLE**

**Hoist type:**

**SX5 022...DH**

**SI-60Hz**

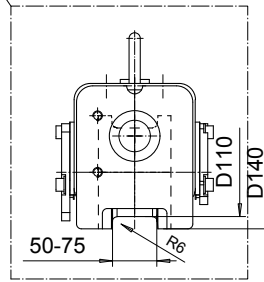
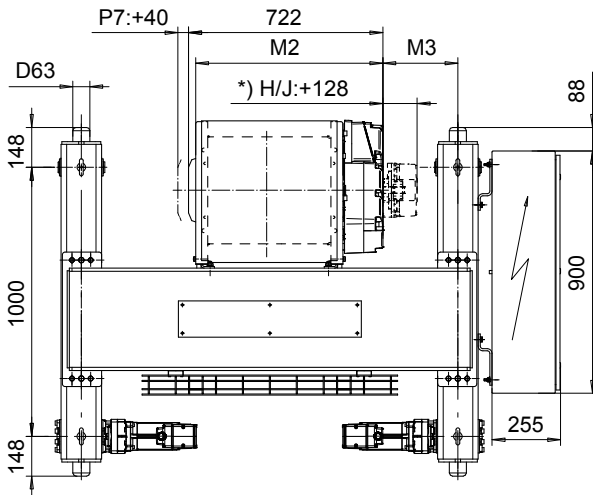
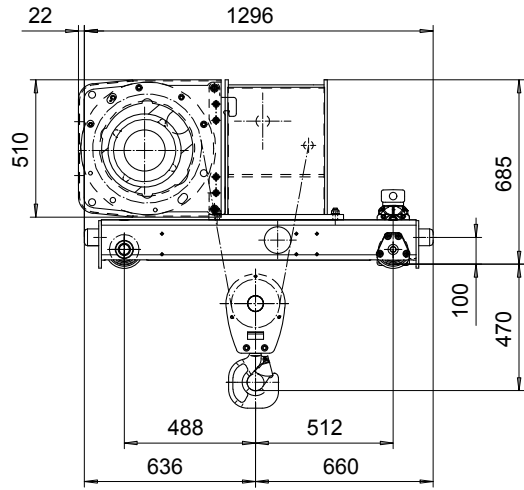
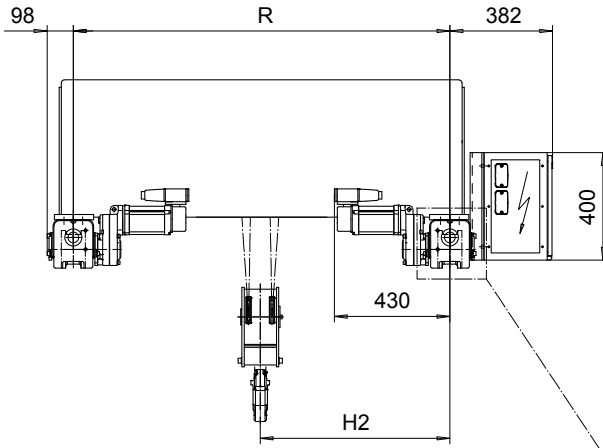

Load (kg)	Class Fem/ISO	Hoisting speed (m/min)		
		Gear+Motor code:		
		F+P5	H+P6	J+P7
4000	3m/M6	12/2	19/3.2	24/4
5000	2m/M5	12/2	19/3.2	24/4
+ weight (kg):		-	30	40

HOL (m)	Length code	M2 (mm)	M3 (mm)	H2 (mm)	min R (mm)	Weight (kg)
8.5	D	697	179	605	1200	750
13	E	817	117	605	1200	775
18	F	967	143	705	1400	835
25	G	1157	197	855	1700	915
33.5	H	1407	105	855	1700	959
46	J	1757	256	1211	2400	1125

Note: minR is minimum rail gauge when second brake is supplied  
 Standard rail gauges are 1200, 1400, 1700, 2000, and 2400 mm.  
 The brake is mounted on the gearcase for drum length H and J.

This document is the absolute property of R&M Materials Handling, Inc. This document must not be copied without the written permission of R&M Materials Handling, Inc. The contents thereof must not be disclosed to a third party nor be used for any unauthorized purpose. Contravention will be prosecuted.

ETTATA Design	ETTAV Chd	Appd	Ref Drawing	QC-H-22
2002-10-16 Date	TROLLEY; DOUBLE GIRDER			1 of 12 Folder
SLEQDCV Owner Dept	HIGH, 2x2 ROPE FALLS			
R&M MATERIALS HANDLING, INC. HOIST & CRANE PRODUCTS	D002243-A			Issue 4