

**DOUBLE GIRDER, HIGH CONNECTION, 4 PART DOUBLE**  
**Hoist type:**  
**SX5 042...DH**

SI-60Hz

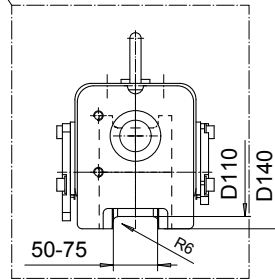
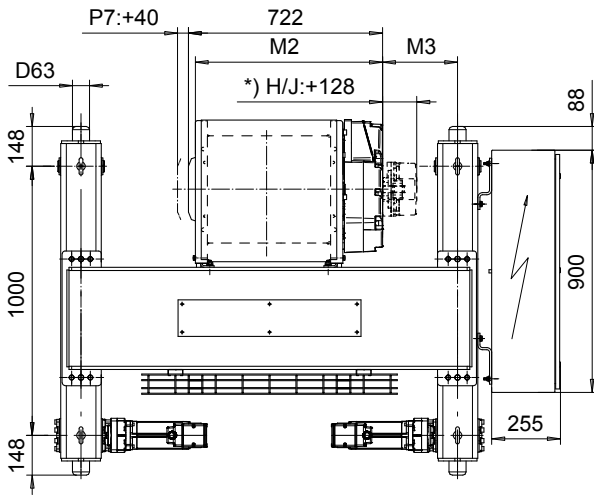
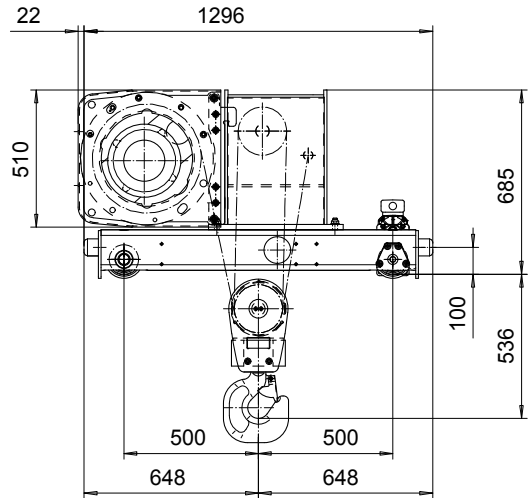
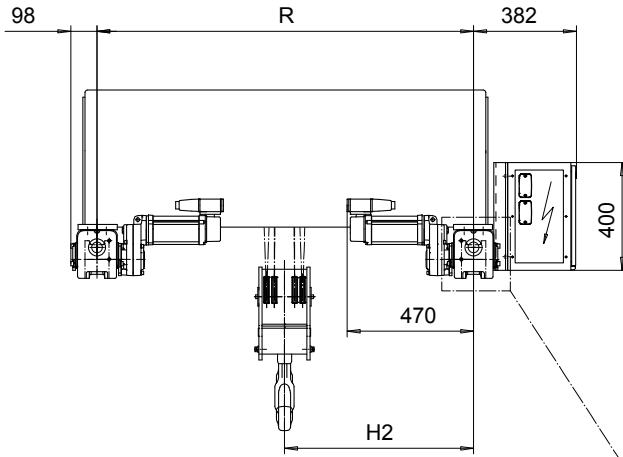

Load (kg)	Class Fem/ISO	Hoisting speed (m/min)		
		Gear+Motor code:		
		F+P5	H+P6	J+P7
6000	3m/M6	6/1	9.5/1.6	12/2
8000	3m/M6	6/1	9.5/1.6	12/2
10000	2m/M5	6/1	9.5/1.6	12/2
+ weight (kg):		-	30	40

HOL (m)	Length code	M2 (mm)	M3 (mm)	H2 (mm)	min R (mm)	Weight (kg)
4	D	697	179	605	1200	810
6.5	E	817	117	605	1200	835
9	F	967	143	705	1400	895
12.5	G	1157	197	855	1700	975
16.5	H	1404	105	855	1700	1019
23	J	1757	256	1211	2400	1185

Note: minR is minimum rail gauge when second brake is supplied  
 Standard rail gauges are 1200, 1400, 1700, 2000, and 2400 mm.  
 The brake is mounted on the gearcase for drum length H and J.

This document is the absolute property of R&M Materials Handling, Inc. This document must not be copied without the written permission of R&M Materials Handling, Inc. The contents thereof must not be disclosed to a third party nor be used for any unauthorized purpose. Contravention will be prosecuted.

ETTATA	ETTAV	Appr	Ref Drawing	QC-H-24
Design	Chd			
2002-10-17				
Date	TROLLEY; DOUBLE GIRDER			1 of 12
SLEQDCV	HIGH, 2x4 ROPE FALLS			Folder
Owner Dept				
R&M	R&M MATERIALS HANDLING, INC.			Issue
	HOIST & CRANE PRODUCTS			4
	D002244-A			