

DOUBLE GIRDER, HIGH CONNECTION, 6 PART DOUBLE
Hoist type:
SX5 062...DH

SI-60Hz

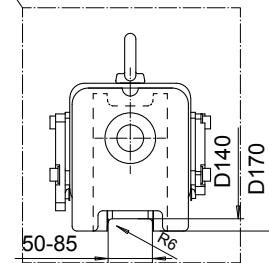
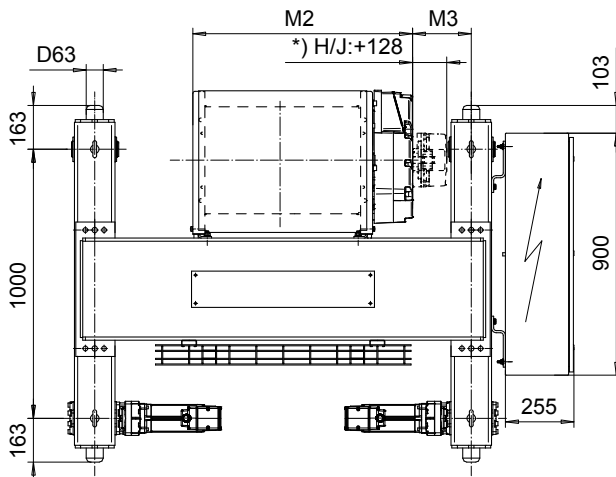
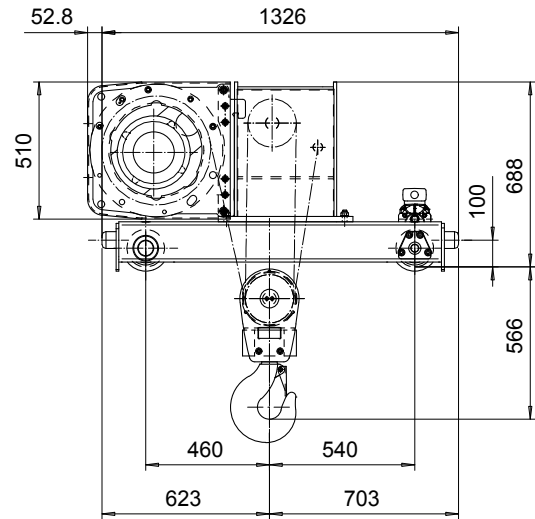
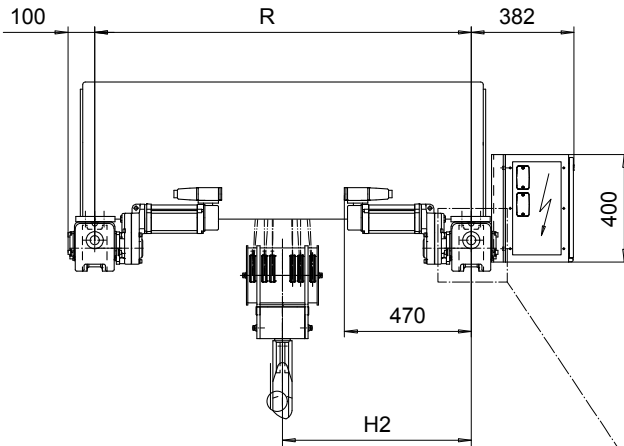

Load (kg)	Class Fem/ISO	Hoisting speed (m/min)		
		Gear+Motor code:		
		F+P5	H+P6	J+P7
12000	3m/M6	3.8/0.6	6/1	7.5/1.3
15000	2m/M5	3.8/0.6	6/1	7.5/1.3
+ weight (kg):		-	30	40

HOL (m)	Length code	M2 (mm)	M3 (mm)	H2 (mm)	min R (mm)	Weight (kg)
4	E	817	117	605	1200	860
6	F	967	143	705	1400	920
8	G	1157	197	855	1700	1000
11	H	1404	105	855	1700	1045
15	J	1757	256	1211	2400	1210

Note: minR is minimum rail gauge when second brake is supplied
 Standard rail gauges are 1200, 1400, 1700, 2000, and 2400 mm.
 The brake is mounted on the gearcase for drum length H and J.

This document is the absolute property of R&M Materials Handling, Inc. This document must not be copied without the written permission of R&M Materials Handling, Inc. The contents thereof must not be disclosed to a third party nor be used for any unauthorized purpose. Contravention will be prosecuted.

ETTATA Design 2002-10-17 Date	ETTAV Chd Appd	Ref Drawing	QC-H-26
SLEQDOCV Owner Dept	TROLLEY; DOUBLE GIRDER HIGH, 2x6 ROPE FALLS		1 of 12 Folder
R&M R&M MATERIALS HANDLING, INC. HOIST & CRANE PRODUCTS	D002245-A		Issue 4