

DOUBLE GIRDER, MEDIUM, 2 PART SINGLE
Hoist type:
SX6 021...D0

SI-60Hz

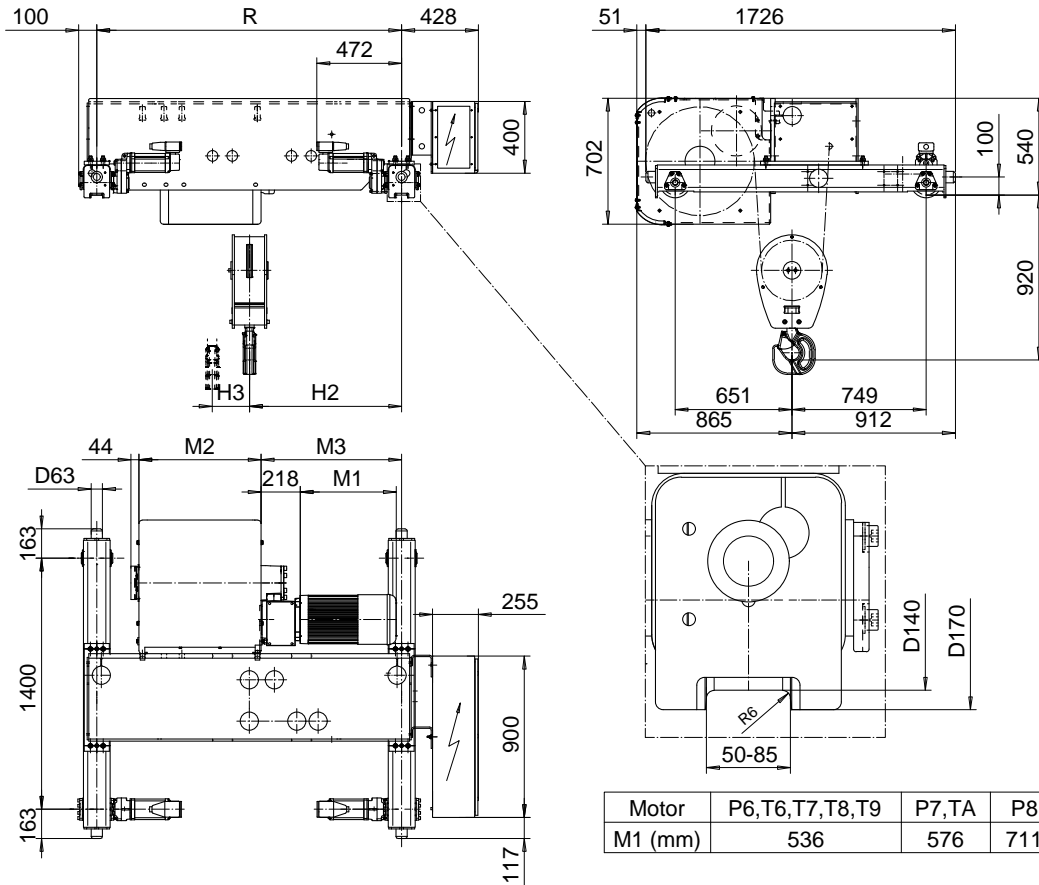

HOL	Length	M2	M3	H2	H3	min R-max R	Weight
(m)	code	(mm)	(mm)	(mm)	(mm)	(mm)	(kg)
15.5	C	462	658	723	139	1400-2400	1600
21	D	562	784	859	188	1700-2400	1700
28	E	682	784	859	251	1700-3100	1740
36	F	832	934	985	322	2000-3800	1860
47	G	1022	1144	1141	421	2400-4200	2020
61	H	1272	1480	1468	546	3100-4200	2210
80.5	J	1622	1544	1567	721	3400-4200	2510
97	K	1922	1970	1929	868	4200-4200	2870

Load (kg)	Class Fem/ISO	Hoisting motor				
		Hoisting speed (m/min): Gear code				
		9.5/1.6: E	12/2: F	15/2.5: G	19: H	24: J
6300	3m/M6	P6,T6	P6,T6	P7,T7	T8	T9
8000	2m/M5	P6,T6	P6,T6	P7,T7	T8	T9
10000	1Am/M4	P6,T6	P7,T7	P8,T8	T9	TA

Note: minR is minimum rail gauge when service platform is supplied
 Standard rail gauges are 1400, 1700, 2000, 2400, 2700, 3100, 3400
 3800, and 4200 mm
 H2, M3 and weight calculated at minR

This document is the absolute property of R&M Materials Handling, Inc. This document must not be copied without the written permission of R&M Materials Handling, Inc. The contents thereof must not be disclosed to a third party nor be used for any unauthorized purpose. Contravention will be prosecuted.

ETFPAL Design	ETFPAL Chd	Appd	Ref Drawing	QD-M-02
2002-09-02 Date	TROLLEY; DOUBLE GIRDER			1 of 18 Folder
SLEQDOCV Owner Dept	MEDIUM, 2 ROPE FALLS			
R&M MATERIALS HANDLING, INC. 5000 S. 1000 E. ST. SPRINGFIELD, OH 45504	D002142-A			Issue 5